



LeghornGroup

Protection - Control - Identification - Tracking
Since 1978

Security seals



PROTECTION – CONTROL – IDENTIFICATION - TRACKING

3. LeghornGroup's vision and value
3. Who we are

BOLT LOCK SEALS ISO 17712:2013

5. NEPTUNSEAL STANDARD

BARRIER SEALS ISO 17712:2013

6. FORKSEAL C.

7. NEW FORKSEAL

8. BLOCKBAR

CABLESEALS ISO 17712:2013

13. CABLESEAL da 3,5 mm

14. CABLESEAL da 4 mm

15. CABLESEAL da 5 mm

CABLESEALS NORMAL

9. CABLESEAL da 1 mm

10. CABLESEAL da 1,5 mm

11. CABLESEAL da 2,5 mm

12. CABLESEAL da 3 mm

METAL STRAPSEAL

16. BALLOONSEAL

17. METALSEAL

18. STRAPSEAL

NUMBERED SECURITY SEALS USED WITH SEALING WIRE

(ALUMINUM)

19. CRIMPSEAL (METAL)

20. CRALUSEAL (METAL)

21. CRALUPLIER

23. ALLUSEAL

NUMBERED SECURITY SEALS USED WITH SEALING WIRE

(PLASTIC)

24. PLOMBEX

25. ANCHORCLICK

26. ANCHORFLAG

27. TWISTSEAL

28. TRITON

RING PLASTIC STRAPSEAL

30. CARSEAL

31. HORNSEAL 215

32. HORNSEAL 260

33. RINGLABELSEAL 215

34. RINGLABELSEAL 260

PLASTIC ADJUSTABLE SECURITY SEALS

(100% PLASTIC)

35. TWIGGYSEAL 2,2x190 (laser print)

36. TWIGGYSEAL 2,2x255 (laser print)

37. EASYTIGHT 6x294 (ink transfer print)

38. BAGSEAL 6x420 (ink transfer print)

39. SIMPLESEAL 6x294 (laser print)

40. LONGSEAL 6x420 (laser print)

41. TITANSEAL 5x328 (ink transfer print)

42. TITANSEAL 5x424 (ink transfer print)

43. HERACLIS 5x298 (ink transfer print)

44. HERACLIS 5x394 (ink transfer print)

45. ORION 5x258 (ink transfer print)

46. ORION 5x354 (ink transfer print)

47. ADJUSTSEAL 3,3x315 (ink transfer print)

48. ADJUSTSEAL 3,3x425 (ink transfer print)

PLASTIC ADJUSTABLE SECURITY SEALS (METAL LOCK)

29. MEROPESEAL 1mm

29. ALCYONESEAL 1mm

49. SCITSEAL 3,3 mm

50. SCITSEAL LGH 103 2mm

51. FRISSOSEAL double numbering 2x315

52. JUPITER 1,3x225

53. JUPITER 2,315

54. JUPITER 2x425

55. JUPITER 3,3x315

56. JUPITER 3,3x425

57. HECTORSEAL 7,5x430

DRUM SEALS

58. DRUMLOCK

TOTE BOX SEAL

59. TOTEBOX SEAL 37x16

60. POSTAL BLOCK

SECURITY SEALS FOR SECURITY BAGS

61. ZIP STOP STANDARD AND BARCODE

UNNUMBERED SECURITY SEALS

22. URANUS SEAL FOR FIRE EXTINGUISHER

24. PLOMBEX

OTHER PLASTIC PRODUCTS

62. CONNECTIONLOCK

SEALING WIRES

63. GALVANIZED STEEL WIRE 1 mm

64. STAINLESS STEEL WIRE 1 mm

65. COPPER SEALING WIRE 1mm

66. BRASS SEALING WIRE 1 mm

67. NYLON COPPER SEALING WIRE 1 mm

68. STAINLESS STEEL SEALING CABLE - Plastic covered

69. STEEL WIRE, PLASTIFIED

70. NYLON WIRE, PLASTIFIED

PLASTIC PRODUCTION

70.

NOTE:

In both factories in Italy and in Czech Republic we usually have in stock approximately 8,000,000 security seals printed with "SEALED" + numbering.

Shipment in 1 day.

We can ship in one or two days small volume customized orders.

(Platinum delivery)

We can ship in 7-10 days medium volume customized orders.

(Gold delivery)

We can ship in 20-25 days large volume customized orders.

(Normal delivery)



President's Statement

"The most important contribution that a company can offer to social progress is to manage its activities in the most efficient possible way.

*This means never losing sight of the values that are the foundation of any civil society. **LeghornGroup** has always been and continues to be engaged in activities that we believe are inseparable from our daily operations in the security sector, such as educational programs, donations and social commitment. "*

Luciano Grapsa – President and CEO **LeghornGroup** srl

Aim

LeghornGroup's main aim is to operate efficiently, lucratively and responsibly in the security and anti tampering sector.

LeghornGroup's desire to be a focus point within this sector is supported by its strong commitment to manufacture and develop innovative and highly effective solutions

Responsibilities

LeghornGroup srl has five major areas of responsibility:

1. Towards its partners, protecting their investments and guaranteeing returns.
2. Towards our customers, taking care of existing clients, developing relations with new customers and maintaining their loyalty by offering a variety of products and good value services in terms of price, quality, safety and minimal environmental impact.
3. Towards its staff and employees, by respecting their rights and offering good working conditions, ensuring their full personal and professional satisfaction. Promote and make the most of their talent and ensure equal employment opportunity; encourage their staff's involvement in the planning and management of their work and the daily application of the corporate vision and values
4. Towards all parties with whom the company establishes business relations. Ensure mutual benefits with contract partners and suppliers, and promote the application of these vision and values. The desire to promote these vision and values will be a determining factor in deciding whether to establish or maintain such relationships.
5. Towards the community. Conduct its business as responsible members of society, respecting the legislations where here **LeghornGroup** srl operates. Expressing its support for fundamental human rights, in line with its legitimate role of private enterprise, paying attention to the health, safety and the environment, whilst showing commitment to sustainable development.



LeghornGroup s.r.l. established 1978 is a manufacturer and supplier of security seals and security products for protecting assets. Specializing in applications for shipping and logistics.

Thanks to a wealth of experience and it's in house design and production capabilities, LeghornGroup can provide a decisive and comprehensive response to every security related issue.

Its varied range of products, systems and bespoke solutions has allowed LeghornGroup to establish as one of the European leaders of this sector. With sales offices in Europe, USA Latin American and the Middle East with

production plants for plastic molding and metal parts, LeghornGroup has complete control over its range of products and an extensive worldwide client support network.

Furthermore, the company's computer and electronics division within the group have been working for over ten years to enhance LeghornGroup' security products with the most innovative technical features. Their aim: to protect our assets, data and information and make a better future for all of us.

LeghornGroup is committed to protecting goods and assets from tampering or pilferage, by using the most suitable solution (be it mechanical, electronic or a combination) providing not only maximum security but guaranteeing economic efficiency.

To achieve this goal LeghornGroup delivers:



Protection. LeghornGroup can protect your goods and assets with security seals and various products for tamper protection. The company can create bespoke, technical solutions to meet client's requirements.



Control. LeghornGroup ensures goods and people can be monitored using security products and integrated complete hardware and software solutions that allow the operator to monitor and intervene in real time, even remotely.



Identification. LeghornGroup's understanding of authentication along with their innovative technical products and solutions allow users to uniquely and securely identify, goods, vehicles, containers, animals and people.



Tracking. LeghornGroup's real time GPS tracking devices allow users to monitor location, status and movements of vehicles and people.

LeghornGroup also manufactures:

Solutions for product authenticity;

Automatic identification systems using RFID to aid traceability of objects, animals and people, offering new and efficient operations to speed up the supply chain;

LeghornGroup aim is to be strongly customer focused, and provide a specific solution that completely meets their needs, which may differ from one client to the next. By working closely alongside clients, they are able to experience firsthand their problem and solve it together.

On a daily basis the company not only works to broaden their understanding of some of the many issues related to illegal and criminal activities, but also the means to counteract them. LeghornGroup s.r.l. keeps a detailed data base on their various products in order to assist the police force with their fight against crime.

Furthermore, LeghornGroup provides an active online service to anybody who might need advice or is looking for a specific product within this sector.



NUMBERING AND CUSTOMISATION:

LASER printing
 Sequential numbering up to 15 figures
 Bar-code option
 Data Matrix option
 RFID option
 Customisation up to 20 characters on one line
 Client logo on request
 For substantial orders it's possible to recreate company logo in relief

MATERIAL:

°Plastic parts: polystyrene / ABS

CERTIFICATES:

Compliant with ISO 17712:2013 HSS (high security seal)
 ISO/PAS 17025 LAB APPROVED

AVAILABLE COLORS:

Red – Yellow – Blue – Green – White – Black –
 Orange – Light blue – Grey – Brown – Lilac.

PACKING:

250 seals per carton
 Carton Dimensions : 39x19x16cm
 Carton weight: 13,3 kg

DESCRIPTION:

° **NEPTUNESEAL** is the first bolt type seal of its kind **ISO17712: 2013 approved**, with the internal metal part exceeding 18 mm .

Our innovative (pat. pending) design is characterised by two metal tabs attached to the bolt, which slot securely into the closure canal of the “female” part of the seal.

This amendment to the traditional bolt seal design, requested by the new ISO norms, means it is no longer possible to tamper the “female” part of the seal by spinning it at high speed.

Any Tampering attempt will damage the seal leaving it irreparable.

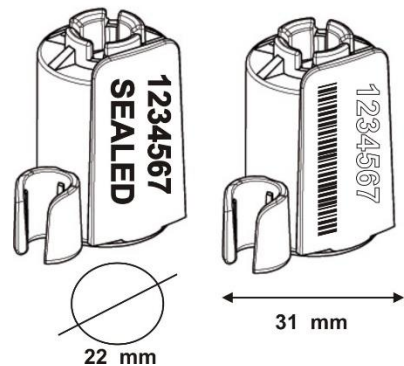
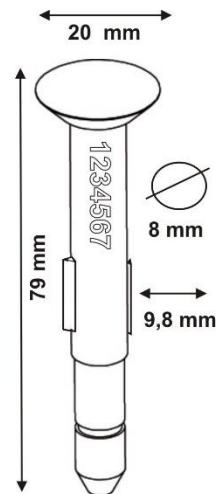

DESCRIPTION:

Anti-terrorism and illegal immigration container protection systems.

The Forkseal® safety locking system protects container doors, guaranteeing 100% security against the ever increasing efforts of illegal immigrants breaking in, as they attempt to be transported to freedom.

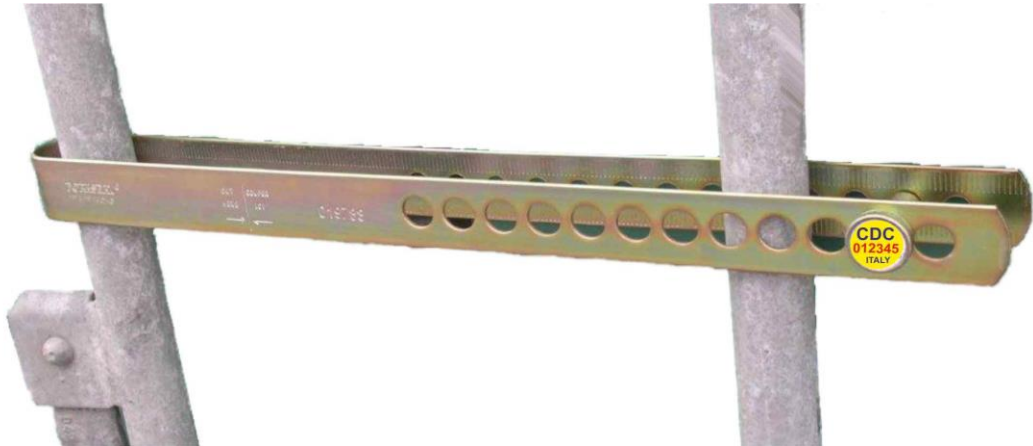

Alongside the ethical concerns, Illegal immigration also causes economical and technical problems which could be avoided by using a safety locking system such as the Forkseal® on the container doors

SEQUENTIAL NUMBERING AND CUSTOMISATION:

- ° Sequenced numbering up to 6 digits.
- ° Alphanumeric numbering possible
- ° Customised up to 20 characters
- ° Logos available upon request
- ° Logos and numbering are also engraved on all metal bar.

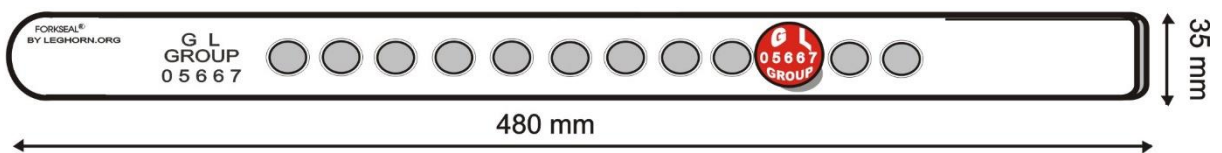

MATERIAL:

Galvanized steel

CERTIFICATIONS:

Compliant with ISO 17712:2013

HSS (high security seal)

WITH ISO 17025 LAB APPROVED

AVAILABLE COLOURS OF LOCKING PIN

Red – Yellow – Blue – Orange – Green – Black – White –

PACKING:

25 seals per carton bagged separately

Carton dimensions: 50x20x15cm

Carton weight: 15 kgs

DESCRIPTION:

The NEW FORKSEAL® is the result Leghorn's many years experience in developing anti-loss, theft and tampering systems for cargo transportation.

The barrier seal can protect containers against the serious threat of illegal immigration, terrorism attempts and break-ins.

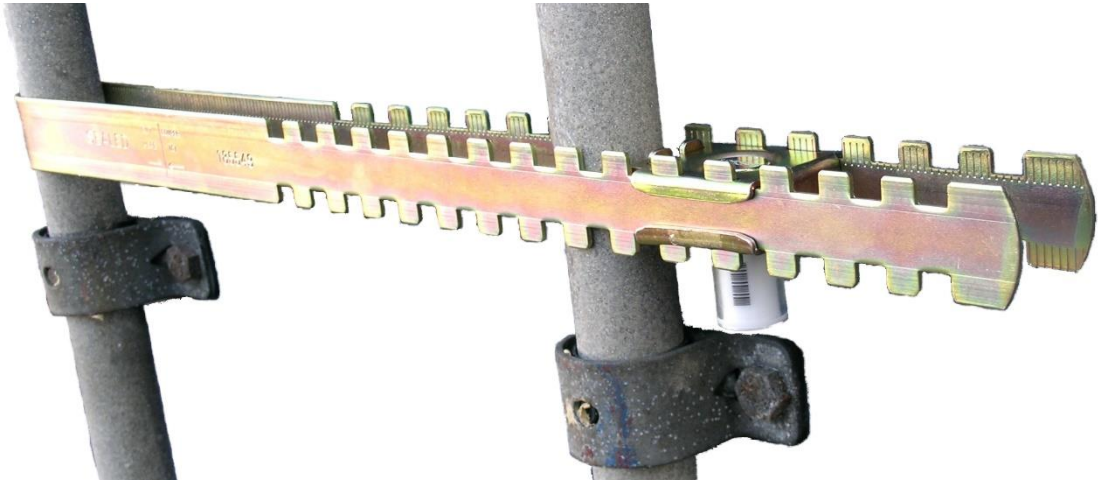

SEQUENTIAL NUMBERING AND CUSTOMISATION:

- ° Logos and numbering are engraved on metal bar and on bolt lock seal (NEPTUNESEAL)
- ° Sequenced numbering up to 6 digits.
- ° Alphanumeric numbering possible
- ° Customised up to 20 characters
- ° Logos available upon request
- ° Bar-code possibility

MATERIAL:

- ° Galvanized steel

AVAILABLE COLOURS OF BOLT LOCK (NEPTUNESEAL)

Red – Yellow – Blue – Green – White –
Black – Orange
Light blue – Grey – Brown – Lilac.

CERTIFICATES:

Compliant with ISO 17712:2013
HSS (high security seal)
ISO/PAS 17025 LAB APPROVED

PACKING:

25 seals per carton bagged separately
Carton dimensions: 50x20x15cm
Carton weight: 15 kgs

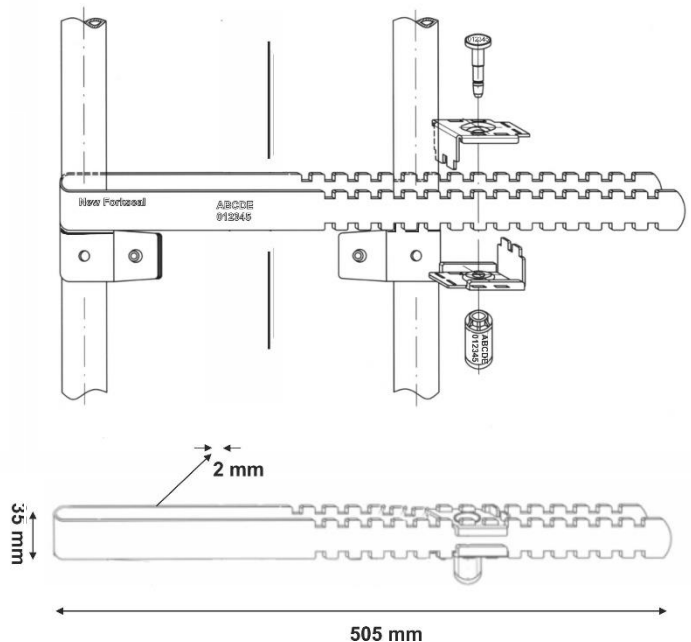



DESCRIPTION:

- ° Adjustable security seals, Barrier seal for containers.
- ° The standard version of Blockbar is the most economic barrier seal to block the central container's bars.

- ° Consequential numbering only on the closure pin.

SEQUENTIAL NUMBERING AND CUSTOMISATION:

- ° METALLIC ENGRAVED
- ° Sequenced numbering up to 6 digits.
- ° Customised up to 10 characters on one line
- ° Logos available upon request

MATERIAL:

- ° Galvanized steel

CERTIFICATIONS:

- ° Compliant with ISO 17712:2013
- HSS (high security seal)
- WITH ISO/PAS 17025
- LAB APPROVED

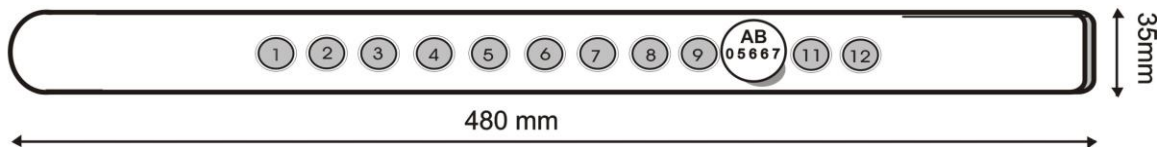

COLORS:

Steel galvanised

PACKING:

- ° Carton with 25 seals
- ° Carton dimensions: 50x20x15 cm
- ° Carton weight: 13,5 kgs

CABLESEAL 1x180 mm

Cableseal – Aluminum body

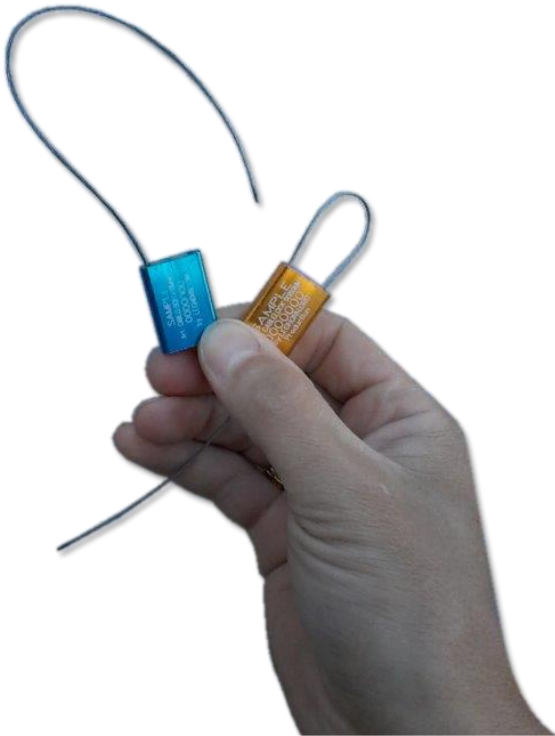

DESCRIPTION:

Security seal, one of the most commonly used. With its cable diameter of 1mm, it can be used in any locking situation. Particularly suitable to control counter meters of electricity, water and gas. The body is completely made in anodised aluminium (*) and a steel cable comes out of it. Once inserted the opposite end of the cable into the hole, and pulled it to the maximum possible extent, there will be no way to open the seal unless by breaking it with good shears.

(*) Anodising is a non- spontaneous electrochemical process by which a protective oxide layer forms on the surface of the treated metal and protects it from corrosion.

DIMENSIONS:

Cable seal (diameter x length): 1x180 mm
Different sizes are available on demand.

NUMBERING AND PERSONALISATION:

Laser etching marking
15 digits sequential numbering
Barcoding
Up to 20 alphanumeric characters per line
Customer's logo

MATERIAL:

Body: Coloured aluminium (anodised)
Steel cable, diameter 1 mm
On demand: stainless steel cable

COLOURS:

Standard colours are:
RED - GREEN - LIGHT BLUE - BLACK - GOLD

PACKAGE:

Quantity per package..... 1000 pieces
Carton size..... 30x28x15 cm
Carton weight..... 8 kg

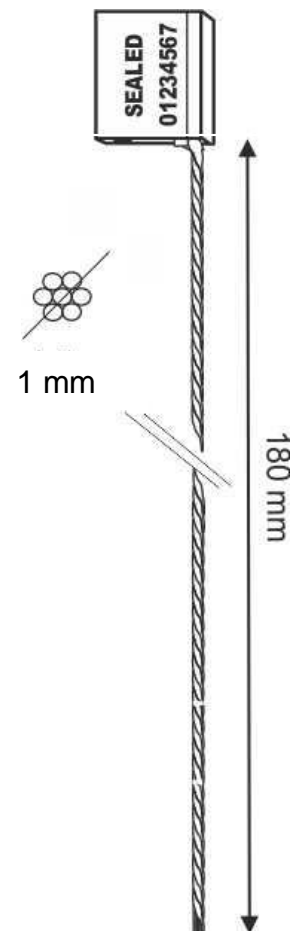

CABLESEAL 1,5x180 mm

Cableseal – Aluminum body

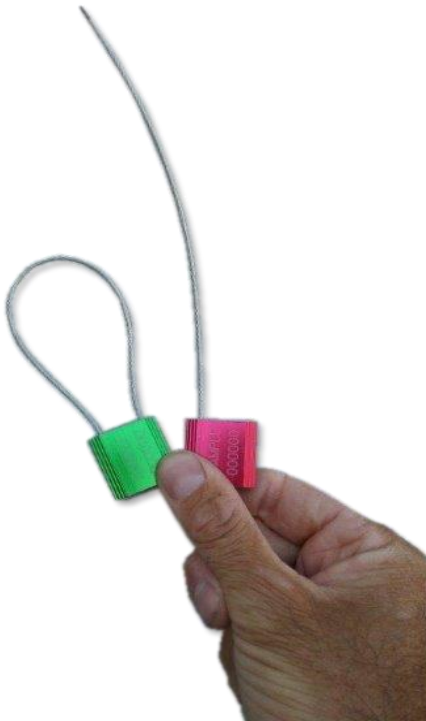

DESCRIPTION:

CABLESEAL with diameter 1,5 mm is a versatile metal security seal that can be used in a large variety of applications.

It is particularly suitable to control counter meters of electricity, water and gas.

The body is completely made in anodised aluminium (*) and a steel cable comes out of it.

Once inserted the opposite end of the cable into the hole, and pulled it to the maximum possible extent, there will be no way to open the seal unless by breaking it with good shears.

(*) Anodising is a non-spontaneous electrochemical process by which a protective oxide layer forms on the surface of the treated metal and protects it from corrosion.

DIMENSIONS:

Cable seal (diameter x length): 1,5 x 180 mm
Different sizes are available on demand.

NUMBERING AND PERSONALISATION:

Laser etching marking
15 digits sequential numbering
Barcoding
Up to 20 alphanumeric characters per line
Customer's logo

MATERIAL:

Body: Coloured aluminium (anodised)
Steel cable, diameter 1,5 mm
On demand: stainless steel cable

COLOURS:

Standard colours are:
RED - GREEN - LIGHT BLUE - BLACK - GOLD

PACKAGE:

Quantity per package.....500 pieces
Carton size.....30x28x15 cm
Carton weight..... 8,6 kg

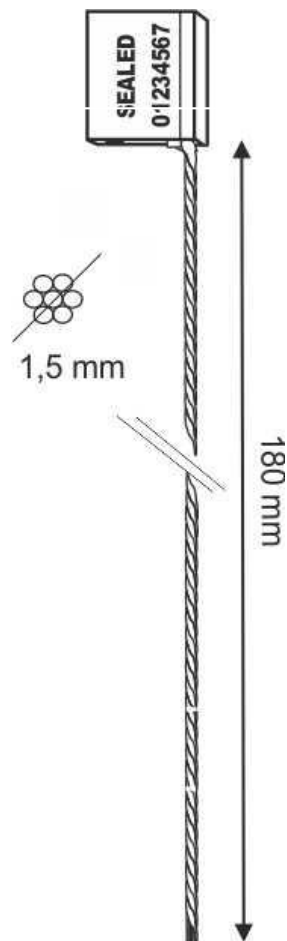

CABLESEAL 2,5x200 mm

Cableseal – Aluminum body

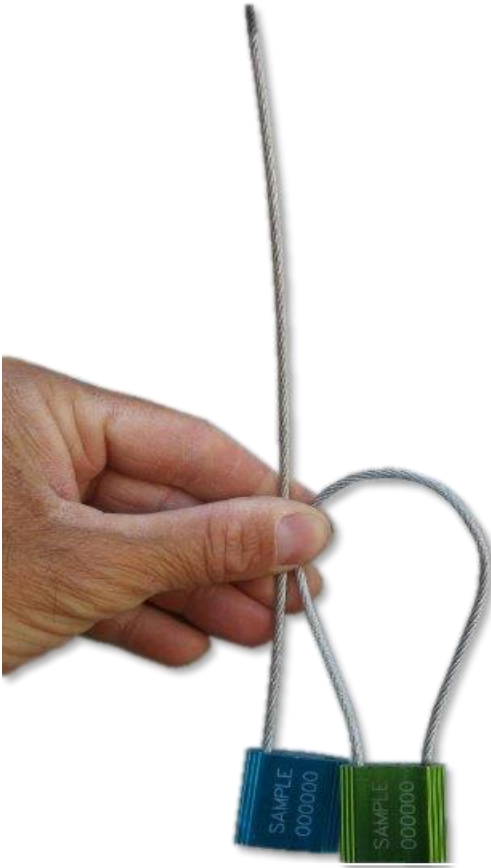

DESCRIPTION:

Very flexible metal security seal. It is an adjustable seal and be used in many different conditions.

It is particularly suitable to lock valves in the industry sector or trucks and oil tankers in transports.

The body is completely made in anodised aluminium (*) and a steel cable comes out of it.

Once inserted the opposite end of the cable into the hole, and pulled it to the maximum possible extent, there will be no way to open the seal unless by breaking it with good shears.

(*) Anodising is a non- spontaneous electrochemical process by which a protective oxide layer forms on the surface of the treated metal and protects it from corrosion.

DIMENSIONS:

Cable seal (diameter x length): 2,5x200 mm
Different sizes are available on demand.

NUMBERING AND PERSONALISATION:

Laser etching marking
15 digits sequential numbering
Barcoding
Up to 20 alphanumeric characters per line
Customer's logo

MATERIAL:

Body: Coloured aluminium (anodised)
Steel cable, diameter 2,5 mm
On demand: stainless steel cable

COLOURS:

Standard colours are:
RED - GREEN - LIGHT BLUE - BLACK - GOLD

PACKAGE:

Quantity per package.....500 pieces
Carton size.....30x28x15 cm
Carton weight..... 9,5 kg

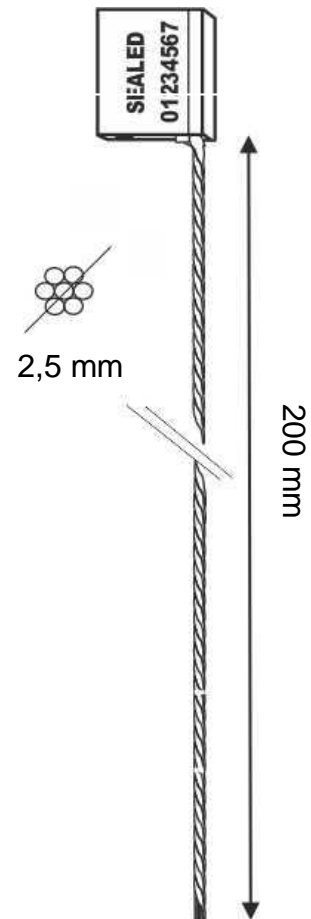

CABLESEAL 3x200 mm

Cableseal – Aluminum body

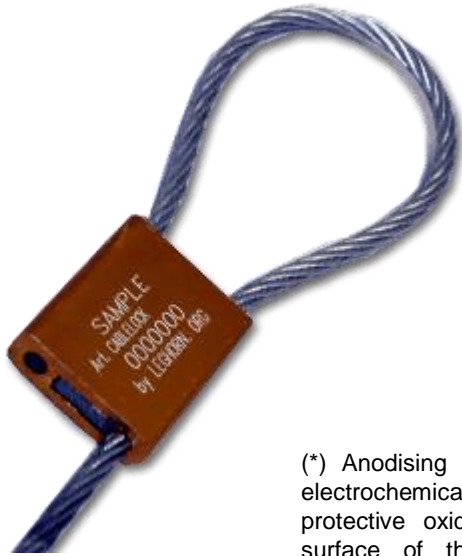

DESCRIPTION:

Very flexible metal security cable seal. It is an adjustable seal and be used in many different conditions.

It is particularly suitable to lock trucks and oil tankers in transports.

The body is completely made in anodised aluminium (*) and a steel cable comes out of it.

Once inserted the opposite end of the cable into the hole, and pulled it to the maximum possible extent, there will be no way to open the seal unless by breaking it with good shears.

(*) Anodising is a non- spontaneous electrochemical process by which a protective oxide layer forms on the surface of the treated metal and protects it from corrosion.

DIMENSIONS:

Cable seal (diameter x length): 3x200 mm
Different sizes are available on demand.

NUMBERING AND PERSONALISATION:

Laser etching marking
15 digits sequential numbering
Barcoding
Up to 20 alphanumeric characters per line
Customer's logo

MATERIAL:

Body: Coloured aluminium (anodised)
Steel cable, diameter 3 mm
On demand: stainless steel cable

COLOURS:

Standard colours are:
RED - GREEN - LIGHT BLUE
BLACK - GOLD

PACKAGE:

Quantity per package.....500 pieces
Carton size.....40x30x18 cm
Carton weight..... 17,5 kg

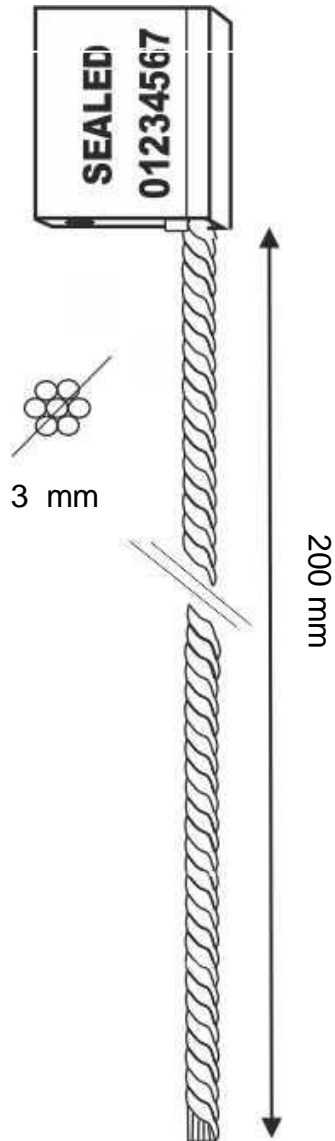



(*) Anodising is a non- spontaneous electrochemical process by which a protective oxide layer forms on the surface of the treated metal and protects it from corrosion.

DESCRIPTION:

Cable seals are metal adjustable seals and as such they are extremely versatile and can be used in a wide set of different applications.

CABLESEAL 3,5x250 mm has the body completely made in anodised aluminium (*) and a steel cable comes out of it.

Once inserted the opposite end of the cable into the hole, and pulled it to the maximum possible extent, there will be no way to open the seal unless by breaking it with good shears.

Specifically CABLESEAL 3,5x250mm is suitable to meet security requirements in container shipping or rail transport.

DIMENSIONS:

Cable seal (diameter x length): 3,5x250 mm
Different sizes are available on demand.

NUMBERING AND PERSONALISATION:

Laser etching marking
15 digits sequential numbering
Barcoding
Up to 20 alphanumeric characters per line
Customer's logo

MATERIAL:

- Body: Coloured aluminium (anodised)
- Steel cable, diameter 4 mm
- On demand: stainless steel cable

COLOURS:

Standard colours are:
RED - GREEN - LIGHT BLUE – BLACK - GOLD

CERTIFICATES:

Compliant with ISO 17712:2013 HSS (high security seal)
ISO/PAS 17025 LAB APPROVED

PACKAGE:

Quantity per package.....500 pieces
Carton size.....39x29x19 cm
Carton weight..... 19,2 kg

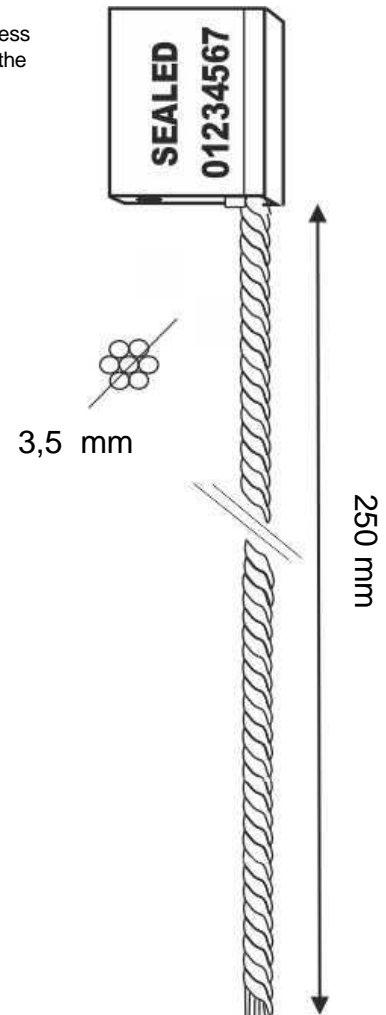

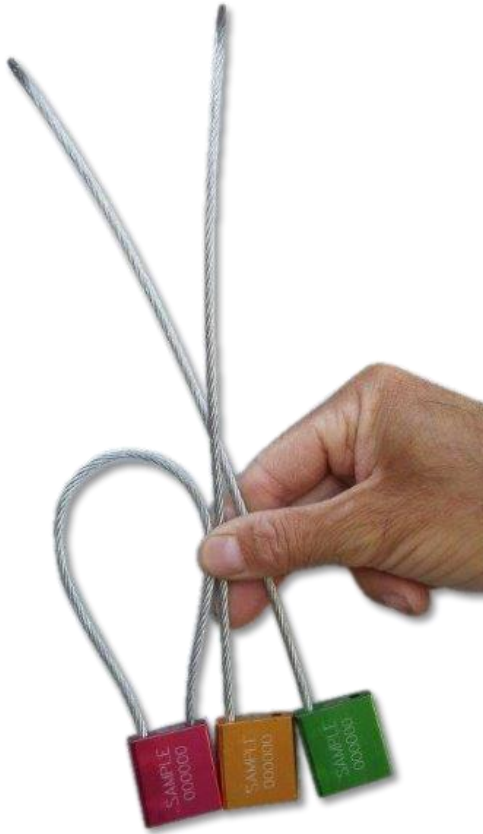

DIMENSIONS:

Cable seal (diameter x length): 4x250 mm
Different sizes are available on demand.

NUMBERING AND PERSONALISATION:

Laser etching marking
15 digits sequential numbering
Barcoding
Up to 20 alphanumeric characters per line
Customer's logo

MATERIAL:

- Body: Coloured aluminium (anodised)
- Steel cable, diameter 4 mm
- On demand: stainless steel cable

COLOURS:

Standard colours are:
RED - GREEN - LIGHT BLUE – BLACK - GOLD

CERTIFICATES:

Compliant with ISO 17712:2013 HSS (high security seal)
ISO/PAS 17025 LAB APPROVED

PACKAGE:

Quantity per package.....500 pieces
Carton size.....39x29x19 cm
Carton weight..... 19,6 kg

DESCRIPTION:

Cable seals are metal adjustable seals and as such they are extremely versatile and can be used in a wide set of different applications.

CABLESEAL 4x250mm has the body completely made in anodised aluminium (*) and a steel cable comes out of it.

Once inserted the opposite end of the cable into the hole, and pulled it to the maximum possible extent, there will be no way to open the seal unless by breaking it with good shears.

Specifically CABLESEAL 4x250mm is suitable to meet security requirements in container shipping or rail transport.

(*) Anodising is a non-spontaneous electrochemical process by which a protective oxide layer forms on the surface of the treated metal and protects it from corrosion.

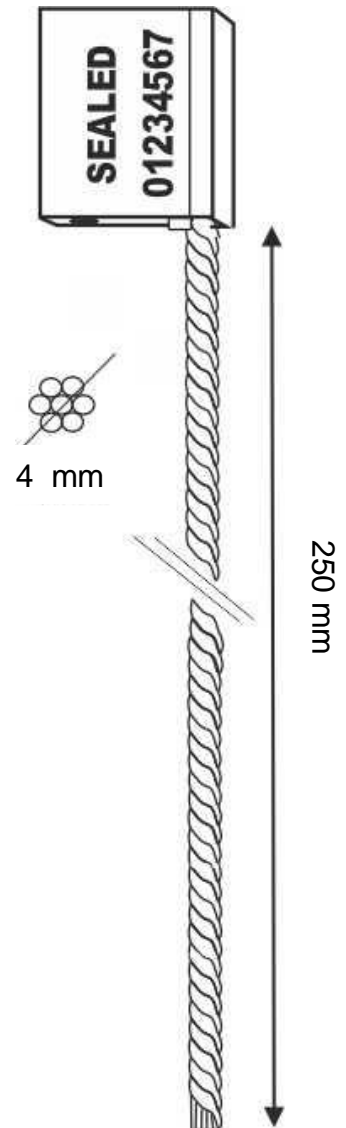

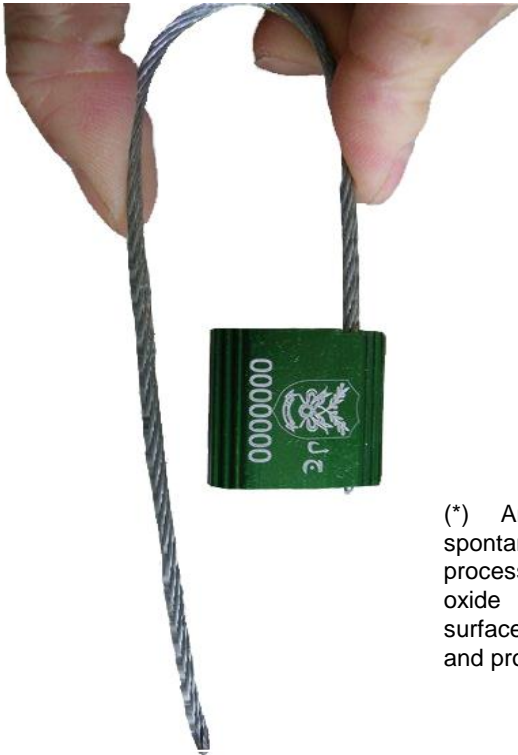

DESCRIPTION:

Cable seals are metal adjustable seals and as such they are extremely versatile and can be used in a wide set of different applications.

CABLESEAL 5x250mm has the body completely made in anodised aluminium (*) and a steel cable comes out of it. Once inserted the opposite end of the cable into the hole, and pulled it to the maximum possible extent, there will be no way to open the seal unless by breaking it with good shears.

Specifically CABLESEAL 5x250mm is suitable to meet security requirements in container shipping or rail transport.

(*) Anodising is a non-spontaneous electrochemical process by which a protective oxide layer forms on the surface of the treated metal and protects it from corrosion.

DIMENSIONS:

Cable seal (diameter x length): 5x250 mm
Different sizes are available on demand.

NUMBERING AND PERSONALISATION:

Laser etching marking

15 digits sequential numbering

Barcoding

Up to 20 alphanumeric characters per line

Customer's logo

MATERIAL:

- Body: Coloured aluminium (anodised)

- Steel cable, diameter 5 mm

- On demand: stainless steel cable

COLOURS:

Standard colours are:

RED - GREEN - LIGHT BLUE – BLACK - GOLD

CERTIFICATES:

Compliant with ISO 17712:2013 HSS (high security seal)

ISO/PAS 17025 LAB APPROVED

PACKAGE:

Quantity per package.....250 pieces

Carton size.....39x29x19 cm

Carton weight..... 16,2 kg

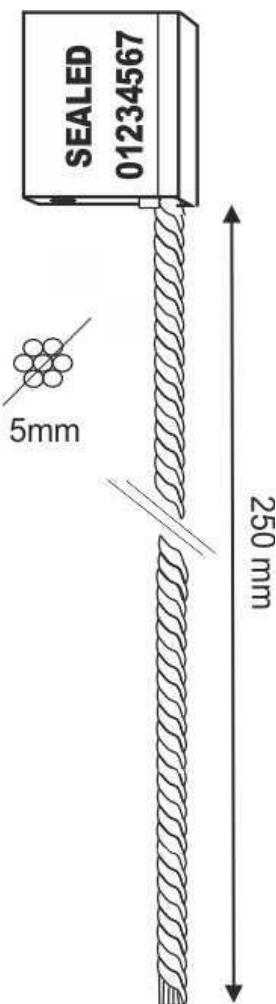



DESCRIPTION:

Balloon seal is perhaps the most secure type of metal strap seal, due to the blocking system. The seal's tail is inserted into the head/balloon part and the internal double steel spring clamps the tail in place.

After the seal has been blocked, it's impossible to reopen it without breaking it and leaving any evidence of tampering.

SIZES:

- ° Width : 9,5 mm
- ° Length : 215 mm

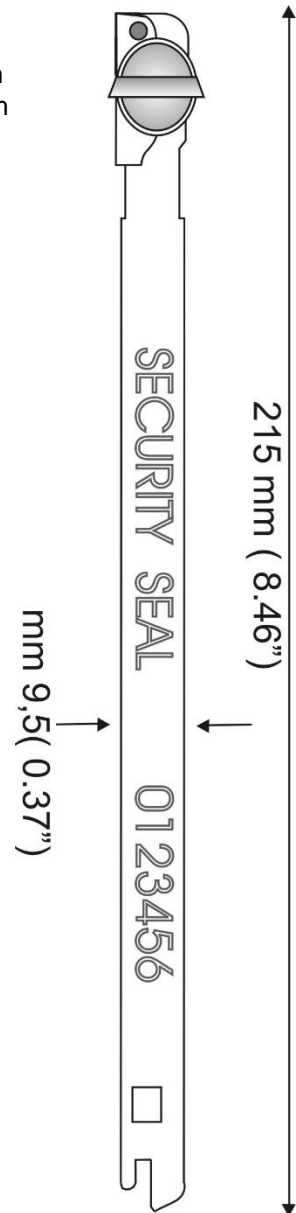

SEQUENTIAL NUMBERING AND CUSTOMISATION:

- ° RELIEF PRINTED
- ° Sequenced numbering up to 7 digits.
- ° Customised up to 16 characters on one line
- ° Logos available upon request
- ° The customisation and numbers are printed in relief directly on the metal strap

MATERIAL:

- ° Plated aluminium

PACKING:

- Carton with 1000 seals per carton divided into bags of 100 sequential numbered seals
- Carton dimensions: 39.5x29x20 cm (15.55"x11.41"x7.9")
- Carton weight: 8,5 kg

METALSEAL

Metal strap seal



DESCRIPTION:

° Metal strap seals for container use.
The METALSEAL is our most economical strap seal

SIZES:

° Width : 8 mm
° Length : 217 mm

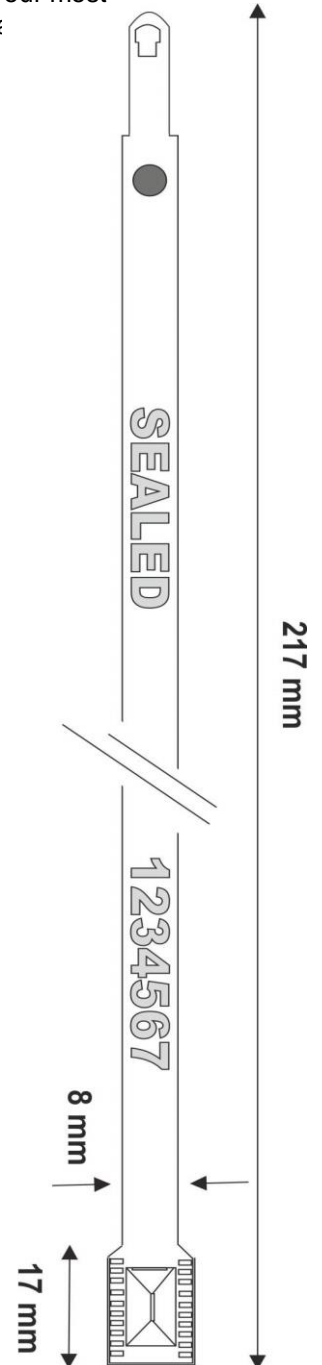

SEQUENTIAL NUMBERING AND CUSTOMISATION:

- ° RELIEF PRINTED
- ° Sequenced numbering up to 7 digits.
- ° Customised up to 20 characters on one line
- ° Logos available upon request
- ° The customisation and numbers are printed in relief directly on the metal strap

MATERIAL:

- ° Plated Aluminium

PACKING:

1000 seals per carton divided into bags of 100 sequentially numbered pieces

Carton dimensions: 32x22x12 cm
(12.6"x8.7"x4.7")

Carton weight: 4 kg (8.8 pounds)



DESCRIPTION:

The cargo container identification seal STRAPSEAL offers an extreme security and high visibility even from a longer distance and is easy to handle. Our STRAPSEAL is also suitable for freight containers, vehicle doors and TIR cables. Can be produced in various lengths from 10 to 115 cm.

STANDARD SIZES:

- ° Width : 7 mm
- ° Length : 210 mm

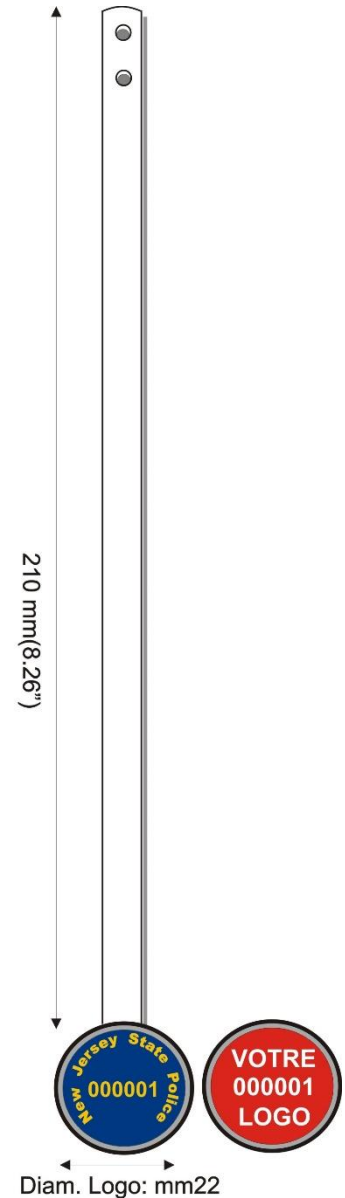

SEQUENTIAL NUMBERING AND CUSTOMISATION:

- ° HOT PRINT
- ° Sequenced numbering up to 6 digits.
- ° Alphanumeric numbering possible
- ° Customised up to 20 characters
- ° Logos available upon request

MATERIAL:

- ° Steel

AVAILABLE COLOURS OF LOCKING PIN

Red – Yellow – Blue – Orange – Green – Black – White –

PACKING:

- 1 carton = 1000 pcs
- Carton dimensions: 29x20x15 cm
- Carton weight: 7 kgs

CRIMPSEAL

Wire security seal



DESCRIPTION:

° Completely aluminium seal.

Self flocking.
to be used with:
sealing wire.
security wire.
custom string.
string.

SIZES:

° Width : 5 mm
° Length : 37 mm (open)
° Length : 19 mm (lo)

SEQUENTIAL NUMBERING AND CUSTOMISATION:

- ° METALLIC ENGRAVED
- ° Sequenced numbering up to 6 digits.
- ° Customised up to 10 characters on one line
- ° Logos available upon request

MATERIAL:

- ° ALUMINIUM
- ° GALVANIZED IRON

AVAILABLE COLOURS

Aluminum - Red - Gold - Blue - Green

PACKING:

- A Carton with 5.000 pcs bulk
- B Carton with 5.000 pcs. in bags of 1000 pcs.
- C Carton with 10.000 pcs. bulk
- D Carton with 10.000 pcs. in bags of 1000 pcs.
- E Carton with 5.000 pcs. in strips of 20 pcs.
- F Carton with 10.000 pcs. in strips of 20 pcs.



OPEN

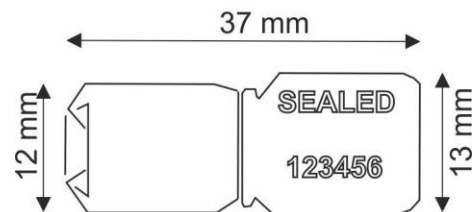

LOCKED (side a)

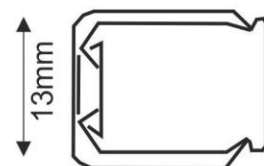

LOCKED (side b)

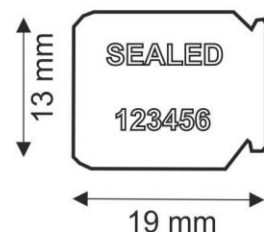



DESCRIPTION :

- ° The Craluseal is a secure and extremely economical seal.
- ° Once the seal's flag has been pressed around the wire with pliers, it's impossible to reopen the seal again without destroying it.
- ° Completely aluminium security seal numbered in sequence.
- ° Supports the following types of sealing wires:
 - Galvanised
 - Copper
 - Brass
 - Nylon-copper

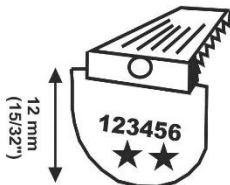

Art 100

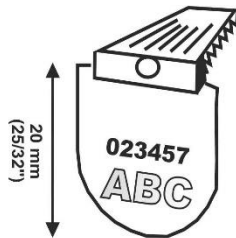

110

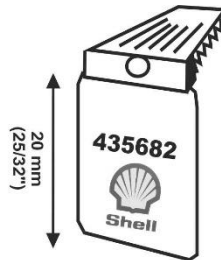

130

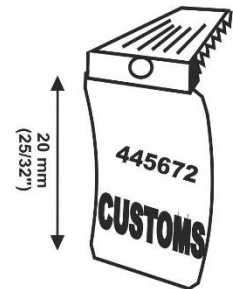

150

SEQUENTIAL NUMBERING AND CUSTOMISATION:

- ° Sequenced numbering up to 6 digits
- ° Customising with up to 12 characters and authentic reproduction of company logo

MATERIAL.:

- ° Plated Aluminium

STANDARD AVAILABLE COLOURS:

- ° natural aluminium
- ° golden aluminium (galvanized)
- ° green aluminium (galvanized)
- ° blue aluminium (galvanized)

PACKING TYPE 1:

Carton box 1.000 per box in cartons of 10.000 pcs
Carton size: 39x26x35 cm

PACKING TYPE 2:

Plastic bag of 1.000 pcs in cartons of 10.000 pcs

Carton size: 28x32x56 cm

Weight:

Model 100: kg 4,60

Model 110: kg 5,20

Model 130: kg 5,80

Model 150: kg 5,90



DESCRIPTION:

°This plier (CRALUPLIER) closes only an aluminium seal (CRALUSEAL).

° It is mainly used to close boxes or identify meters.

SIZES:

230x170mm

CUSTOMISATION:

Customisation can be made on the pair of pliers
(up to 7 characters)
Embossed logo or text : up to 6 characters

PACKING:

Carton with 1 pcs
Carton dimensions: 28x11x4cm
Carton weight: 0,7 kgs

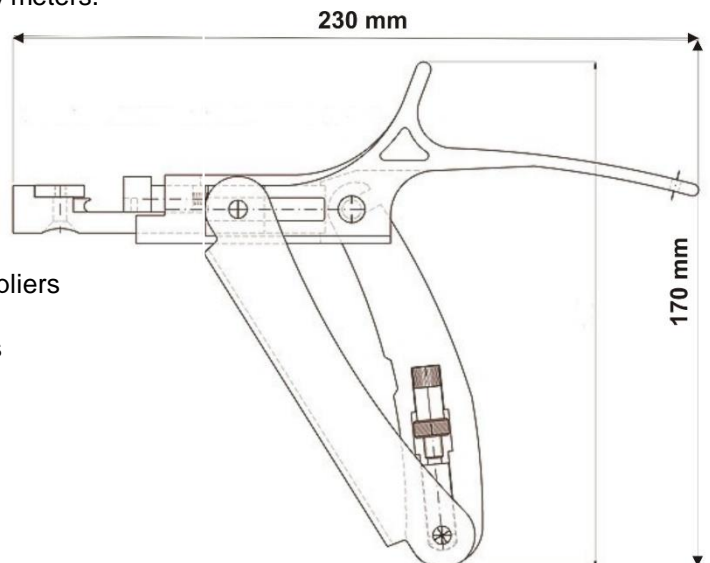

URANUS SEAL

Fire extinguisher security seal

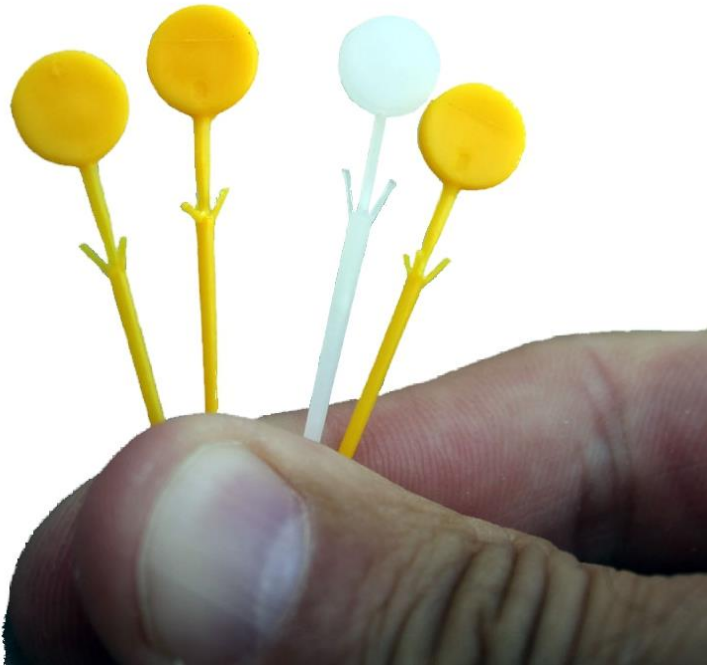

DESCRIPTION:

Plastic seal for fire extinguisher.
It is used as plastic pin to block the fire extinguisher security system.

Easily removable by pulling the seal head up.

Available colours:

RED

YELLOW

Different colours available on demand.

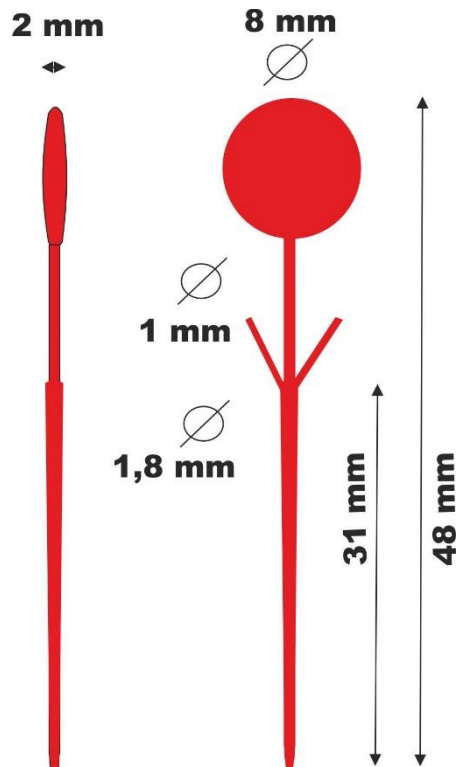

PACKAGE:

Card-board box with 10.000 pieces

Carton sizes : 37x24x13 cm

Carton weight: 2 kg



DESCRIPTION:

° ALLUSEAL to be used with:

sealing wire,
security wire,
custom string,
string.

° Closure guaranteed by using the suitable press.

SIZES:

° diam. Ext. : mm 5
° diam. Inside hole : mm 2
° length : mm 12

CUSTOMISATION:

Using suitable press

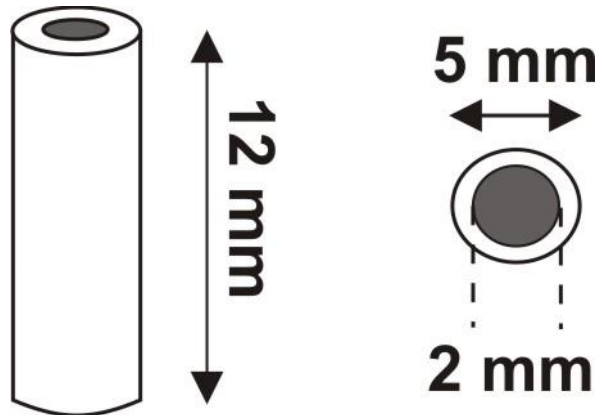

MATERIAL:

° Seals 99,9 % pure aluminium

PACKING:

Carton with 15.000 pcs

Carton dimensions: cm 26x19x22 cm

Carton weight: kgs7,4 kg

**DESCRIPTION:**

° The plastic seals "PLOMBEX" can be used with any kind of rope or metallic wire like:

sealing wire,
security wire,
custom string,
string.

° Custom seals' closure guaranteed by using the suitable press.

SIZES:

° Width : 9 mm or
° Width : 13 mm

CUSTOMISATION:

° Using suitable press.

**AVAILABLE COLORS:**

Red – Yellow – Blue – Green – White – Black - Orange
Light blue – Grey – Brown – Lilac.

PACKING:

PLOMBEX 09 (diam: 9 mm)
carton of 10.000 pcs
Carton dimensions: 21x15x15 cm
Carton weight: 3

PLOMBEX 013 (diam: 13 mm)
carton of 10.000 pcs
Carton dimensions: 35x24x22 cm
Carton weight: 6

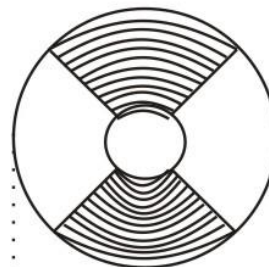
13 mm**9 mm**



DESCRIPTION:

Completely transparent plastic seal.

The transparent plastic permits the integrity control of the locking mechanism.

How to use:

- ° Insert the wire in the holes on the seals' body
- ° Push the "anchor" part in the hole .
- ° Press with the fingers till the seal is really closed. If it clicks by closing the safe closure is guaranteed.

SEQUENTIAL NUMBERING AND CUSTOMISATION:

- ° LASER PRINT
- ° Sequenced numbering up to 15 digits.
- ° Customised up to 20 characters on one line
- ° Logos available upon request
- ° For special orders, logo printing in relief.

MATERIAL:

- ° Polycarbonate
- ° Polystyrene

AVAILABLE COLOURS (TRANSPARENT)

Red – yellow – blue – orange – white - grey – lilac.

PACKING:

Carton with 5000 seals
 Carton dimensions: 56x24x46 H cm
 Carton weight: 10 kgs

SIDE A

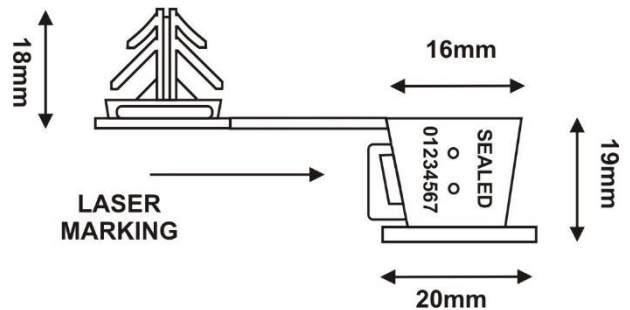

SIDE B

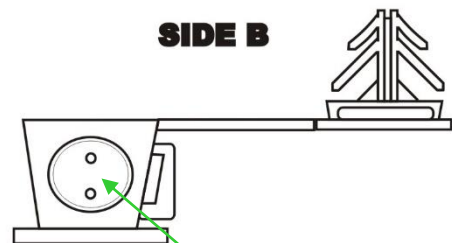

OPTION TO PRINT
 COMPANY LOGO IN RELIEF

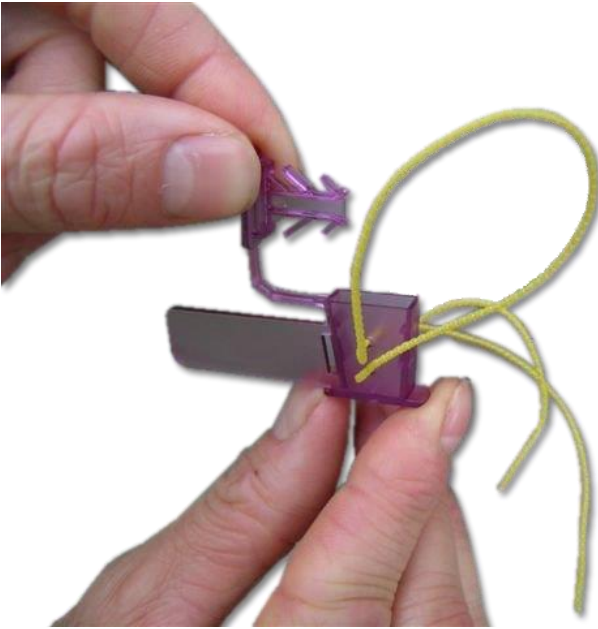

DESCRIPTION:

Completely transparent plastic seal.
The transparent plastic permits the integrity control of the locking mechanism.

How to use:

- ° Insert the wire in the holes on the seals' body
- ° Push the "anchor" part in the hole .
- ° Press with the fingers till the seal is really closed. If it clicks by closing the safe closure is guaranteed.

SEQUENTIAL NUMBERING AND CUSTOMISATION:

- ° LASER PRINT
- ° Sequenced numbering up to 15 digits.
- ° Bar-code possibility
- ° Customised up to 20 characters on one line
- ° Logos available upon request
- ° For special orders, logo printing in relief.

MATERIAL:

- ° Polycarbonate
- ° Polystyrene

AVAILABLE COLOURS (TRANSPARENT)

Red – yellow – blue – orange – white - grey – lilac.

PACKING:

Carton with 4000 seals
Carton dimensions: 56x24x46 H cm
Carton weight: 12 kgs

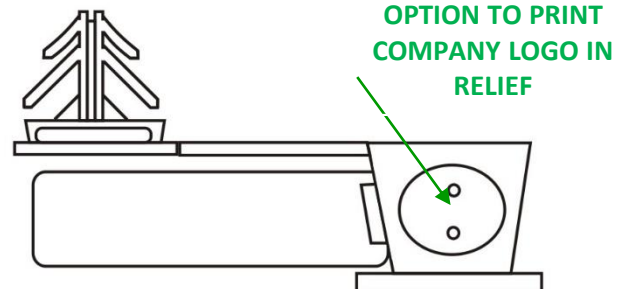
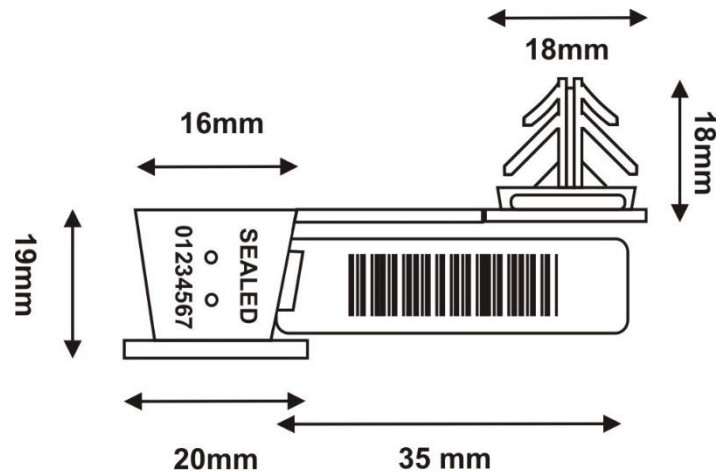



DESCRIPTION:

° Completely plastic seal with incorporated sealing wire. Transparent exterior for better control of the closing mechanism. To close, turn the handle of the seal 360°. Once closed it is advisable to snap off the handle. It is impossible to tamper the seal once it is secured.

° Supports the following types of

sealing wires:

Galvanized

Stainless steel

Brass

Copper

Nylon- copper

SEQUENTIAL NUMBERING AND CUSTOMISATION:

- ° LASER PRINT
- ° Sequenced numbering up to 15 digits.
- ° Bar-code possibility
- ° Customised up to 20 characters on one line .
- ° Logos available upon request
- ° For special orders, logo printing in relief..

MATERIAL:

- ° Polycarbonate
- ° ABS

AVAILABLE COLORS:

Red – Yellow – Blue – Green – White – Black – Orange – Light blue – Grey – Brown – Lilac.

PACKING:

Carton with 1000 seals in bags of 100 pieces numbered in sequence

Carton size: 40x40x15 cm

Carton weight: 4 kgs

-

Carton with 5000 seals in bags of 100 pieces numbered in sequence

Carton size: 60x40x35 cm

Carton weight: 18 kgs

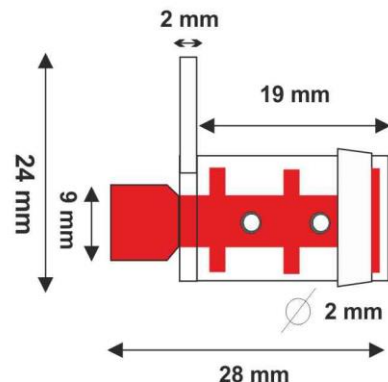
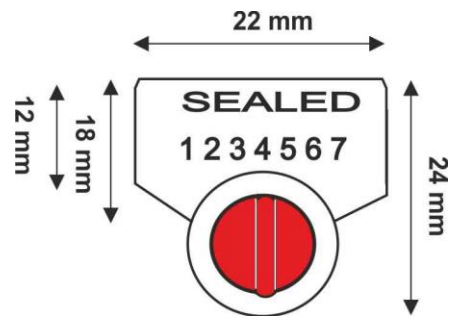



SIZES:

- ° Width : 9 mm
- ° Length : 13 mm
- ° Height : 27 mm

SEQUENTIAL NUMBERING AND CUSTOMISATION:

- °° HOT PRINT
- ° Sequenced numbering up to 7 digits.
- ° Customised up to 20 characters on one line
- ° Logos available upon request

AVAILABLE COLORS:

Red – Yellow – Blue – Green – White – Black – Orange – Light blue – Grey – Brown – Lilac.

PACKING:

- Carton with 1000 seals packed in boxes with each 100 pieces
- Carton dimensions: 40x22x15 cm
- Carton weight: 5 kgs

DESCRIPTION:

- ° TRITONSEAL is a very safe seal. Once positioned and closed, there is no possibility to open it again.
- ° Easy to close with one hand.
- ° Supports the following types of sealing wires:
 - Galvanized
 - Copper
 - Brass
 - Stainless steel
 - Nylon-copper
- ° Galvanized Sealing wire standard length 200 mm

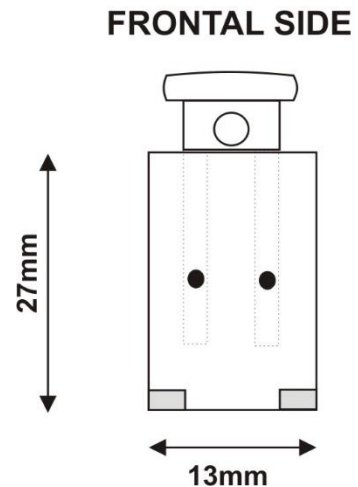
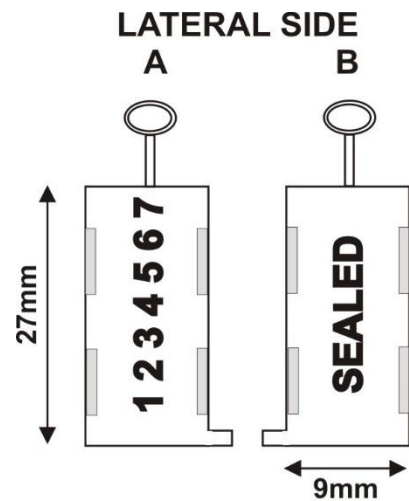

MEROPE SEAL and ALCYONE SEAL

Adjustable plastic seal

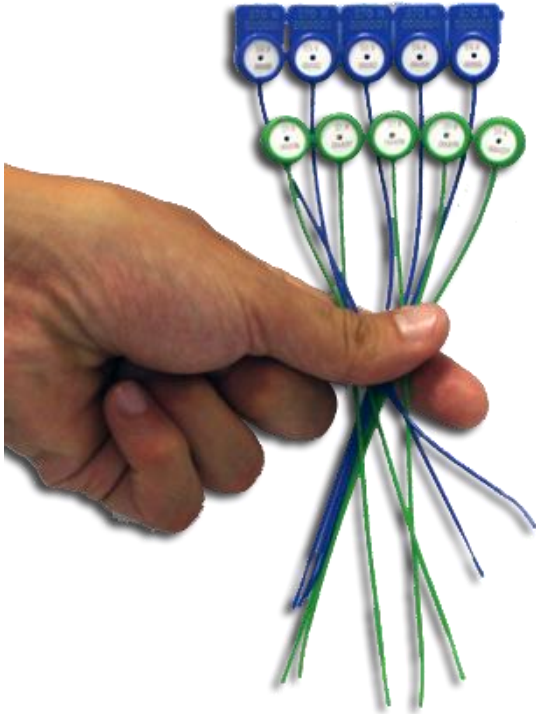

DESCRIPTION:

MEROPE SEAL: with no label on the head

ALCYONE SEAL: with label attached to the head of the seal

MEROPE SEAL and **ALCYONE SEAL** are two nylon seals suitable for utility meters .

The closure system of the seal is made up of a small metal ring that grips the tail of the seal when it is threaded through. Once the sea is applied and closed the only way to open or remove it is by snapping it off.

NUMBERING AND CUSTOMISATION:

- ° Laser print
- ° Numbering up to 7 digits
- ° Customisation up to 3 letters on line.

AVAILABLE COLORS:

Red – Yellow – Blue – Green – White – Black –
Orange – Light blue – Grey – Brown – Lilac.

PACKING:

1 Carton : 1000 pieces
Carton size: 34x30x13 cm
Carton weight: 2 kg

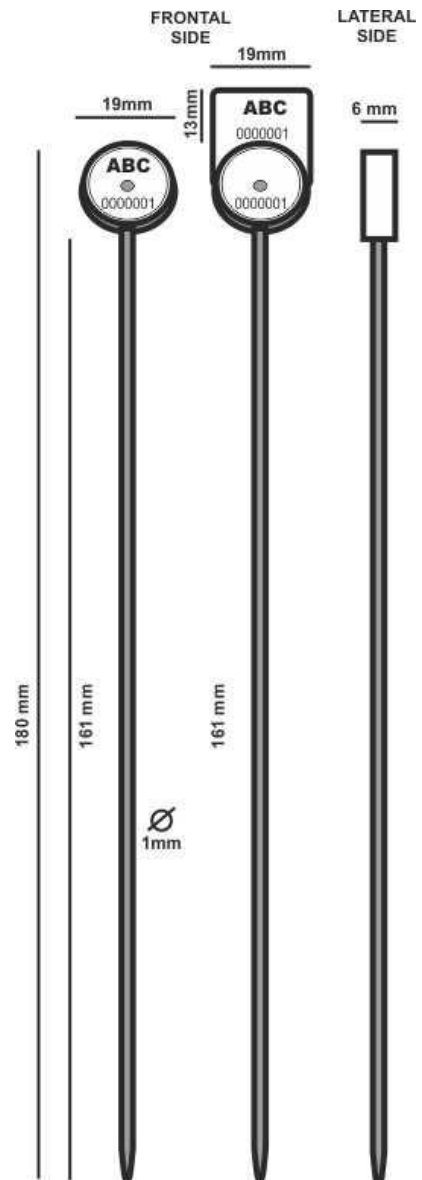



DESCRIPTION:

- ° Plastic security seal.
- ° Specially designed locking teeth for greater security and "Click" sound signifies the seal has been closed correctly.

SIZES:

- ° Width : 8 mm
- ° Length : 225 mm

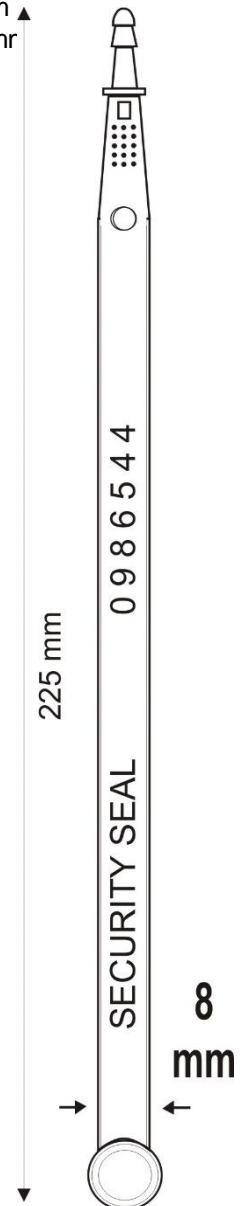

SEQUENTIAL NUMBERING AND CUSTOMISATION:

- ° LASER PRINT
- ° Sequenced numbering up to 15 digits.
- ° Bar-code possibility
- ° Customised up to 20 characters on one line
- ° Logos available upon request
- ° For special orders, logo printing in relief.

MATERIAL:

- ° Polypropylene high density co-polymer.

AVAILABLE COLORS:

Red – Yellow – Blue – Green – White – Black –
Orange – Light blue – Grey – Brown – Lilac.

PACKING:

Carton with 2000 seals - strip of 10 pcs
Carton dimensions: 40x40x24 cm
Weight: 8,5 kgs

HORNSEAL 215 mm

Plastic ring seal



DESCRIPTION:

° Self-locking plastic strap seals. Once closed, there is no way to reopen them without destroying the seal.

° **CALENDAR FUNCTION:**
12 NUMBERS FOR EACH MONTH
31 NUMBERS FOR THE DAYS

SIZES:

° Width : 7 mm

SEQUENTIAL NUMBERING AND CUSTOMISATION:

- ° LASER PRINT
- ° Sequenced numbering up to 15 digits.
- ° Customised up to 20 characters on one line
- ° Logos available upon request
- ° For special orders, logo printing in relief.

MATERIAL:

- ° Polypropylene

AVAILABLE COLORS:

Red – Yellow – Blue – Green – White – Black – Orange – Light blue – Grey – Brown – Lilac.

PACKING:

Carton with 1000 seals - strip of 10 pcs
Carton dimensions: 24x38x19 cm
Weight: 1,9 kg

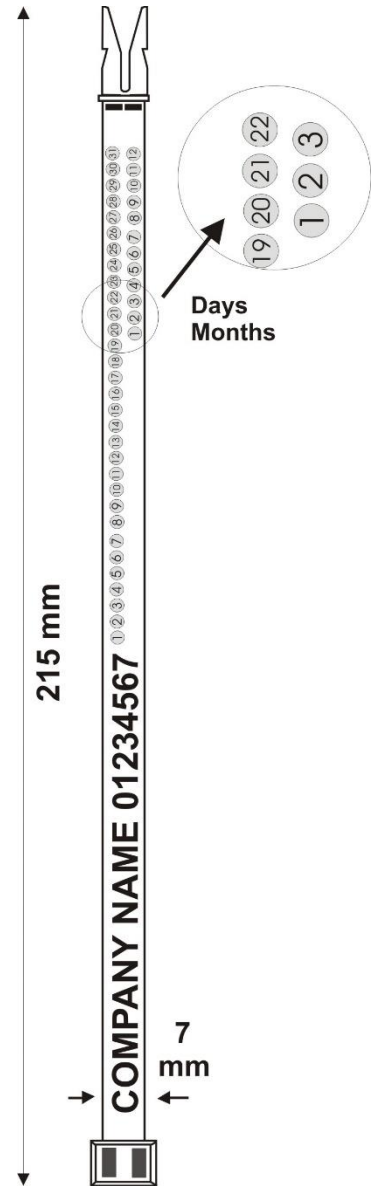

HORNSEAL 260 mm

Plastic ring seal



DESCRIPTION:

° Adjustable plastic strap seals. Once closed, there is no way to reopen them without destroying the seal.

° **CALENDAR FUNCTION:**
12 NUMBERS FOR EACH MONTH
31 NUMBERS FOR THE DAYS

SIZES:

° Width : 7 mm
 ° Length : 260

SEQUENTIAL NUMBERING AND CUSTOMISATION:

- ° LASER PRINT
- ° Sequenced numbering up to 15 digits.
- ° Customised up to 20 characters on one line
- ° Logos available upon request
- ° For special orders, logo printing in relief.

MATERIAL:

- ° Polypropylene

AVAILABLE COLORS:

Red – Yellow – Blue – Green – White – Black – Orange –

PACKING:

Carton with 1000 seals - strip of 10 pcs
 Carton dimensions: 24x38x19 cm
 Weight: 2,4 kg

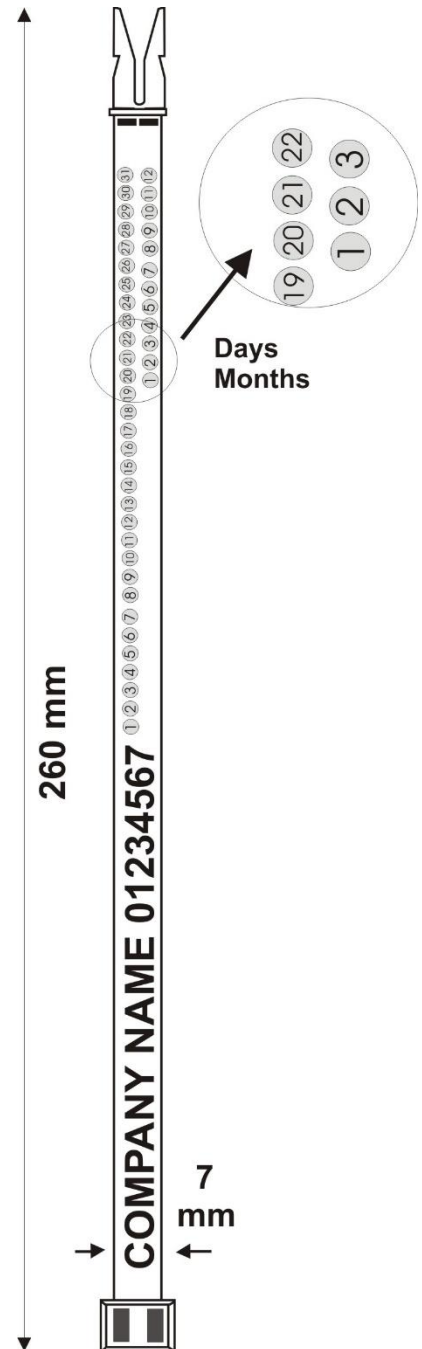

RINGLABELSEAL 215 mm

Plastic ring seal



DESCRIPTION:

° Plastic strap security seals. Once closed, there is no way to reopen them without destroying the seal.

° **CALENDAR FUNCTION:**
12 NUMBERS FOR EACH MONTH
31 NUMBERS FOR THE DAYS

SIZES:

° Width : 7 mm
° Length : 215 mm
° Label : 20x40 mm

SEQUENTIAL NUMBERING AND CUSTOMISATION:

- ° LASER PRINT
- ° Sequenced numbering up to 15 digits.
- ° Bar-code possibility
- ° Customised up to 20 characters on one line
- ° Logos available upon request
- ° For special orders, logo printing in relief.

MATERIAL:

- ° Polypropylene

AVAILABLE COLORS:

Red – Yellow – Blue – Green – White – Black – Orange –

PACKING:

Carton with 1000 seals - strip of 10 pcs
Carton dimensions: 37x24x23 cm
Weight: 2,5 kgs

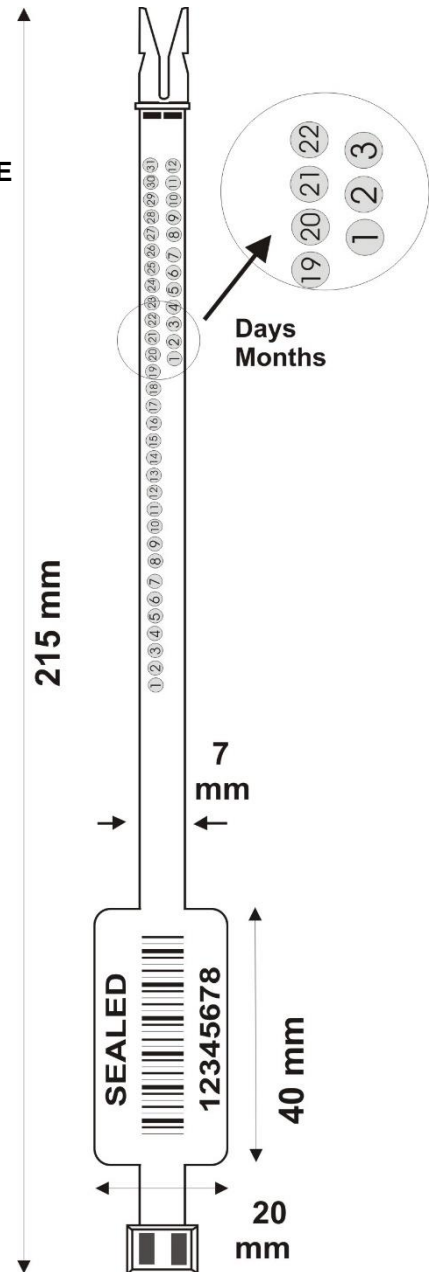

RINGLABELSEAL 260 mm

Plastic ring seal



DESCRIPTION:

- ° Plastic strap security seals.
- Once closed, there is no way to reopen them without destroying the seal.

° **CALENDAR FUNCTION:**
12 NUMBERS FOR EACH MONTH
31 NUMBERS FOR THE DAYS

SIZES:

- ° Width : 7 mm
- ° Length : 260
- ° Label : 20x40 mm

SEQUENTIAL NUMBERING AND CUSTOMISATION:

- ° LASER PRINT
- ° Sequenced numbering up to 15 digits.
- ° Bar-code possibility
- ° Customised up to 20 characters on one line
- ° Logos available upon request
- ° For special orders, logo printing in relief.

MATERIAL:

- ° Polypropylene

AVAILABLE COLORS:

Red – Yellow – Blue – Green – White – Black – Orange –

PACKING:

Carton with 1000 seals - strip of 10 pcs
 Carton dimensions: 37x24x25 cm
 Weight: 2,5 kg

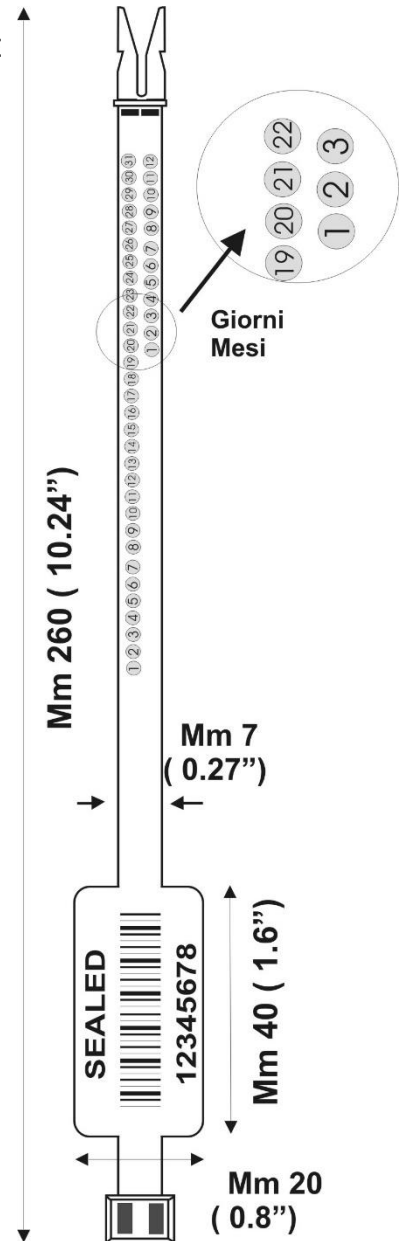

TWIGGY SEAL 2,2x190 mm

Plastic Adjustable seal

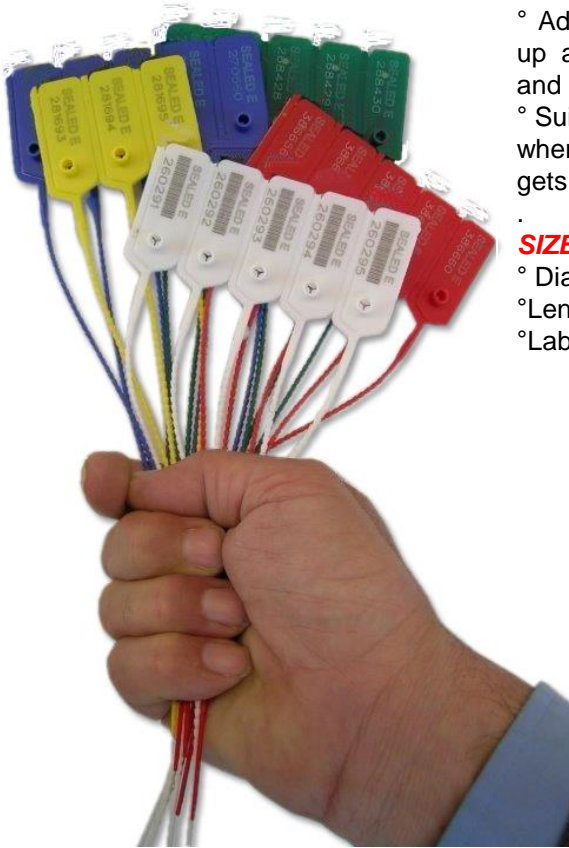

DESCRIPTION:

- ° Adjustable security seals, pull up action for quick application and immediate security.
- ° Suitable for each purpose where you need a seal which gets easily broken.

SIZES:

- ° Diam : 2,2 mm
- ° Length : 190 mm
- ° Label : 22x45 mm

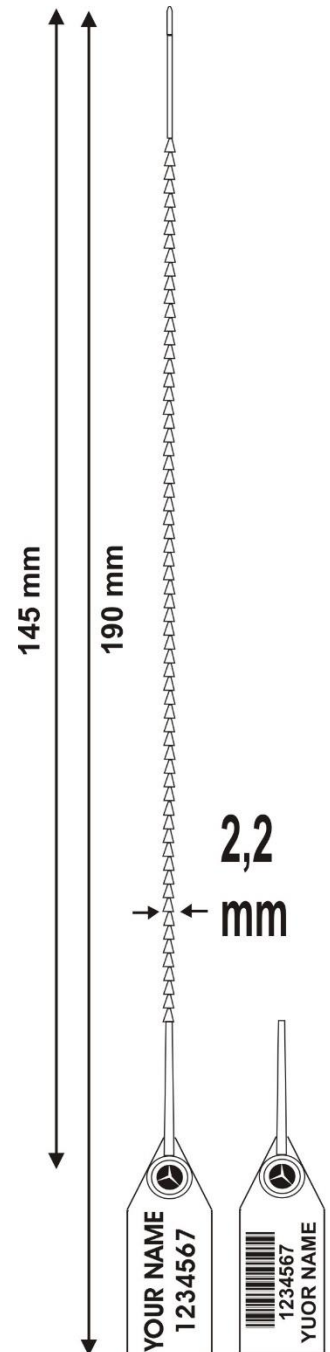

SEQUENTIAL NUMBERING AND CUSTOMISATION:

- ° LASER PRINT
- ° Sequenced numbering up to 15 digits.
- ° Bar-code possibility
- ° Customised up to 20 characters on one line
- ° Logos available upon request
- ° For special orders, logo printing in relief.

AVAILABLE COLORS:

- Red – Yellow – Blue – Green – White – Black - Orange
- Light blue – Grey – Brown – Lilac.
- ° For special orders, logo printing in relief.

PACKING:

- Carton with 1000 seals strip of 10 pcs
- Carton dimensions: 30x24x22 cm
- Carton weight: 1,4 kgs

TWIGGY SEAL 2,2x255 mm

Plastic Adjustable seal

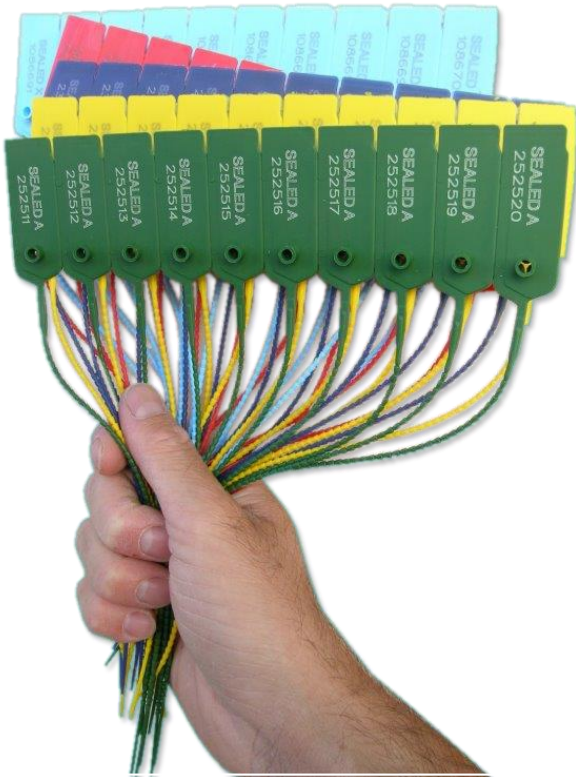

DESCRIPTION:

- ° Adjustable security seals, pull up action for quick application and immediate security.
- ° Suitable for each purpose where you need a seal which gets easily broken.

SIZES:

- ° Diam : 2,2 mm
- ° Length : 210 mm
- ° Label : 22x45 mm

SEQUENTIAL NUMBERING AND CUSTOMISATION:

- ° LASER PRINT
- ° Sequenced numbering up to 15 digits.
- ° Bar-code possibility
- ° Customised up to 20 characters on one line
- ° Logos available upon request
- ° For special orders, logo printing in relief.

AVAILABLE COLORS:

Red – Yellow – Blue – Green – White – Black - Orange
Light blue – Grey – Brown – Lilac.

PACKING:

Carton with 1000 seals strip of 10 pcs
Carton dimensions: 34x24x22 cm
Carton weight: 1,8 kgs

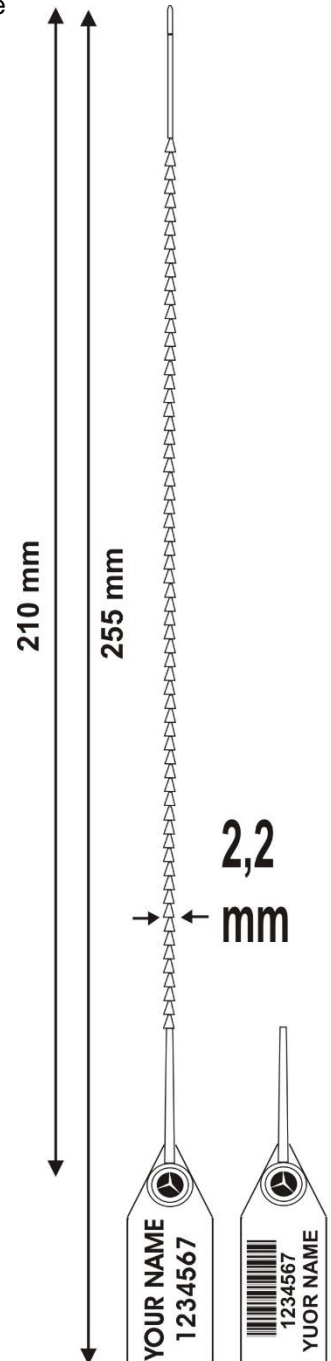

EASYTIGHT 6x294 mm

Adjustable plastic seal – No pre-cut

DESCRIPTION:

This article is manufactured in 100% recyclable plastics.

EASYTIGHT adjustable plastic seal comes as single, one separated from another. In case of need for a bunch of 10 seals joint in a single strip, the following models need to be chosen:

- LONGSEAL
- SIMPLESEAL

EASYTIGHT seal presents a second tail ending into a hole, which can be used to hang additional informative labels.

This seal can be used to close small bags or sacks used for material sample carriage or in transportation, specifically for tarpaulin trucks or tank trucks.

To guarantee the highest security it is necessary to pull tight the seal up to its maximum capability and cut the sticking out tail.

This model is not available as pre-cut option.

To satisfy this requirement you can chose among similar products like:

- LONGSEAL
- SIMPLESEAL



•SIZE:

- Width: 6 mm
- Lenght: 294 mm

NUMBERING AND PERSONALISATION:

Thermal printing:

- Sequential numbering up to 15 digits
- Barcoding
- Up to 20 alphanumeric characters per line
- Customer's logo
- Special customisation on quantities with logo embossing

AVAILABLE COLORS:

Red – Yellow – Blue – Green – White – Black - Orange Light blue – Grey – Brown – Lilac.

For special orders, logo printing in relief.

PACKAGE:

Box with 1.000 singulated pieces – NO STRIP

Box size: 56x39x21 cm

Box weight: 4 kgs

Available on request in bags of 100 sequentially numbered pieces

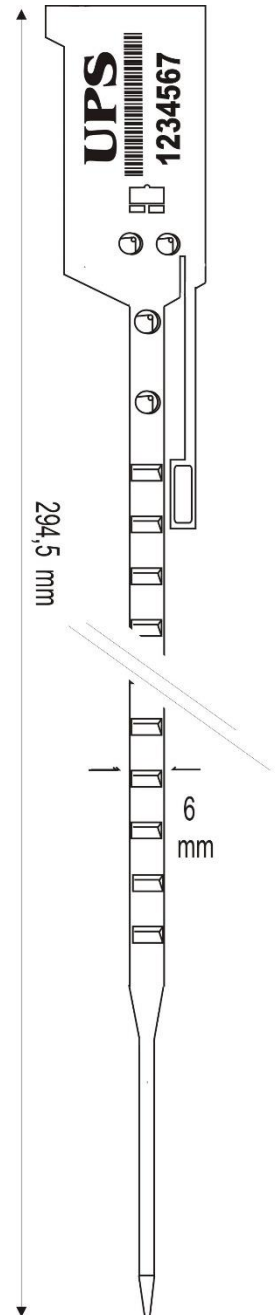

BAGSEAL 6x420 mm

Adjustable plastic seal. – No pre-cut

**SIZE:**

Width: 6 mm
Length: 420 mm

NUMBERING AND PERSONALISATION:

Thermal transfer printing:

- Sequential numbering up to 15 digits
- Barcoding
- Up to 20 alphanumeric characters per line
- Customer's logo
- Special customisation on quantities with embossed logo

AVAILABLE COLORS:

Red – Yellow – Blue – Green – White – Black -
Orange Light blue – Grey – Brown – Lilac.
For special orders, logo printing in relief.

PACKAGE:

Box with 1.000 singulated pieces – NO STRIP
Box size: 56x46x24 cm
Box weight: 5 kgs
Available on request in bags of 100 sequentially
numbered pieces

DESCRIPTION:

Adjustable plastic seal, fully plastic and thus 100% recyclable.

It comes as single item, one seal separated from another.

BAGSEAL presents a second tail ending into a hole, which can be used to hang additional informative labels.

This flexible seal can be used for a wide set of applications, mostly in handling, carriage and transportation, as for example to seal tarpaulin trucks or tank trucks. Very often used also to seal security plastic or cloth bags.

To guarantee the highest security it is necessary to pull tight the seal up to its maximum capability around locking holes or bag necks and cut the sticking out tail.

This model is not available as pre-cut option.

To satisfy this requirement you can chose among similar products like:

LONGSEAL
SIMPLESEAL

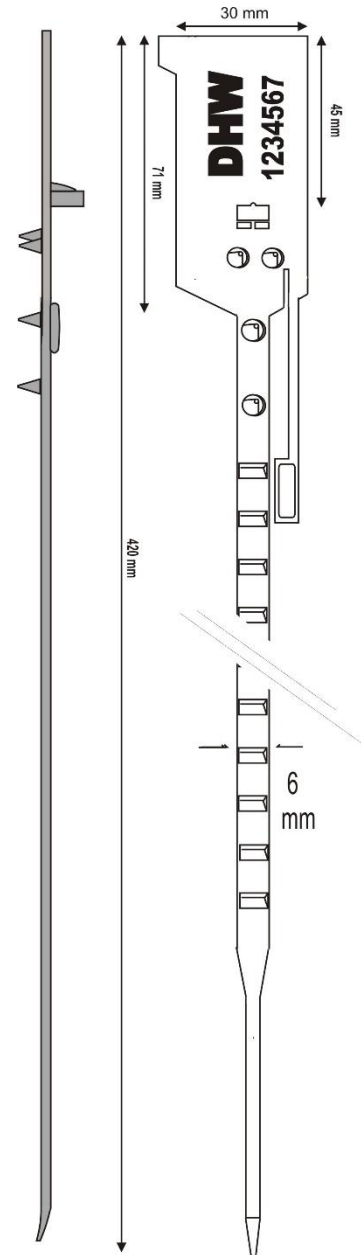

SIMPLESEAL 6x294 mm

Adjustable plastic seal – with tear-off

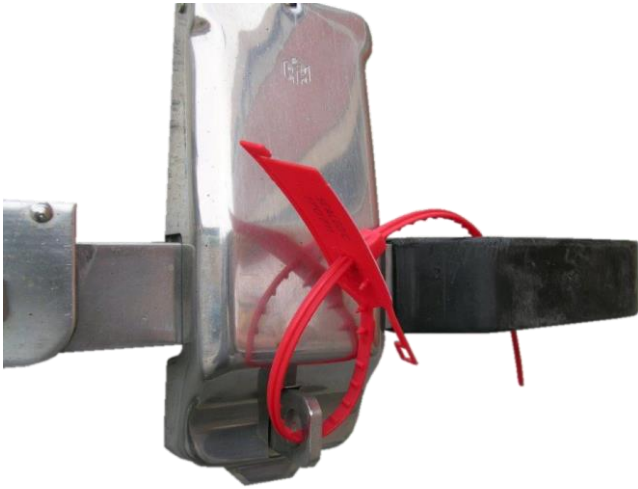

DESCRIPTION:

Adjustable all plastic seal.

SIMPLESEAL is provided in strips of 10 pieces assembled together and sequentially numbered.

SIMPLESEAL seals are pre-cut to avoid using unsafe cutting tools that might injury operators.

Ideal security seals for:

- Tank trucks
- Tarpaulin trucks
- Trailers
- Containers

Very suitable also to seal medium-sized bags or sacks and security bags.

Sided ring can be used to hang additional information label.

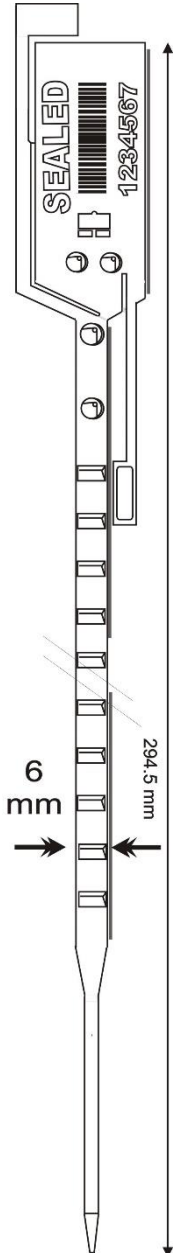

If a longer plastic strap is needed LONGSEAL seal can be used, which has a total length of 420 mm.

As adjustable plastic seal it offers the highest security when tightly pulled up, removing exceeding plastic tail.

SIZE:

Tile width: 6 mm

Total length: 294 mm

NUMBERING AND PERSONALISATION:

Laser printing

15 digits sequential numbering

Barcoding

Up to 20 alphanumeric characters per line

Customer's logo

Special customisation on quantities with embossed logo

MATERIAL:

Copolymer polypropylene

AVAILABLE COLORS:

Red – Yellow – Blue – Green – White – Black - Orange

Light blue – Grey – Brown – Lilac.

° For special orders, logo printing in relief

PACKAGING:

Box of 1.000 pieces in strip of 10 pieces each

Box size: 56x39x21 cm

Box weight: 4 kgs

LONGSEAL 6x420 mm

Adjustable plastic seal- with tear-off



DESCRIPTION:

Adjustable all plastic seal.
 LONGSEAL is provided in strips of 10 pieces assembled together and sequentially numbered.
 LONGSEAL is pre-cut to avoid using unsafe cutting tools that might injury operators.
 It can be used to secure valuables moving by any road transport mean, including tank trucks and tarpaulin trucks.
 Very useful also to seal medium-sized bags.
 Sided ring to hang additional information tag.
 When looking for a shorter tail length please see also LEGHORN SIMPLESEAL model, which has a total length of 294 mm
 To guarantee the highest security it is necessary to pull tight the LONGSEAL up to its maximum capability around locking rings or bag necks and cut the exceeding tail.

SIZE:

Tail width: 6 mm
 Total length: 420 mm

NUMBERING AND PERSONALISATION:

Laser printing
 15 digits sequential numbering
 Barcoding
 Up to 20 alphanumeric characters per line
 Customer's logo
 Special customisation on quantities with embossed logo

MATERIAL:

Copolymer polypropylene

AVAILABLE COLORS:

Red – Yellow – Blue – Green – White – Black - Orange Light
 blue – Grey – Brown – Lilac.
 ° For special orders, logo printing in relief

PACKAGING:

Box of 1.000 pieces in strip of 10 pieces each
 Box size: 56x46x24 cm
 Box weight: 5,5 kgs

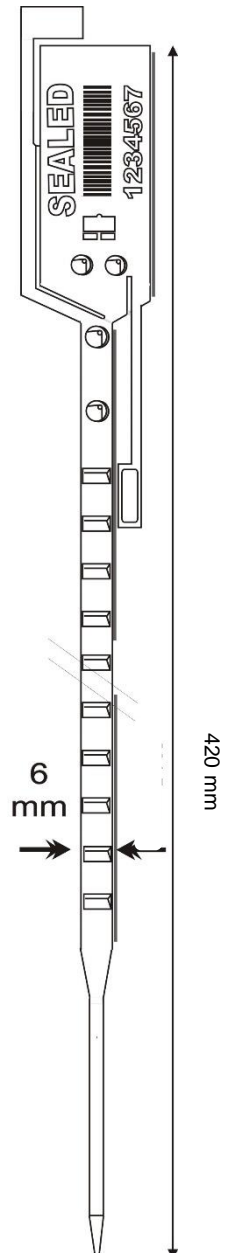

TITANSEAL 5x328 mm

Adjustable plastic seal – Very large label 72x110 mm



DESCRIPTION:

- ° Adjustable security seals, pull up action for quick application and immediate security.
- ° Tear-off possibility or standard version.

SIZES:

- ° Width : 5 mm
- ° Length : 328 mm
- ° Label : 72x110 mm

SEQUENTIAL NUMBERING AND CUSTOMISATION:

- ° INK TRANSFER PRINT
- ° Sequenced numbering up to 15 digits.
- ° Bar-code possibility
- ° Customised up to 20 characters on one line
- ° Logos available upon request
- ° For special orders, logo printing in relief.

AVAILABLE COLORS:

- Red – Yellow – Blue – Green – White – Black -
- Orange Light blue – Grey – Brown – Lilac.
- ° For special orders, logo printing in relief.

PACKING:

- Carton with 500 seals
- Carton dimensions: 47x39x12 cm
- Carton weight: 4,5 kgs

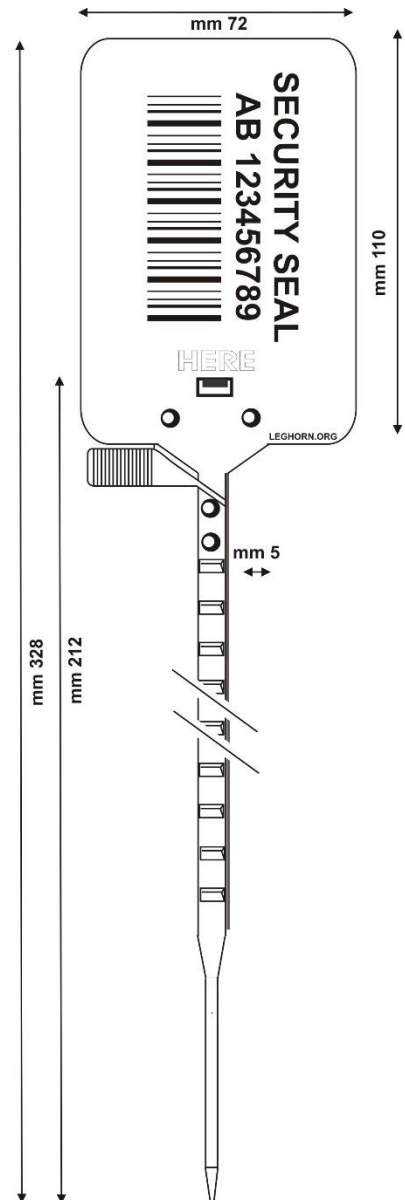

TITANSEAL 5x424 mm

Adjustable plastic seal – Very large label 72x110 mm



DESCRIPTION:

- ° Adjustable security seals, pull up action for quick application and immediate security.
- ° **Tear-off possibility or standard version.**

SIZES:

- ° Width : 5 mm
- ° Length : 424 mm
- ° Label : 72x110 mm

SEQUENTIAL NUMBERING AND CUSTOMISATION:

- ° INK TRANSFER PRINT
- ° Sequenced numbering up to 15 digits.
- ° Bar-code possibility
- ° Customised up to 20 characters on one line
- ° Logos available upon request
- ° For special orders, logo printing in relief.

AVAILABLE COLORS:

- Red – Yellow – Blue – Green – White – Black - Orange Light blue – Grey – Brown – Lilac.
- ° For special orders, logo printing in relief.

PACKING:

- Carton with 500 seals
- Carton dimensions: 56x39x12 cm
- Carton weight: 5 kgs

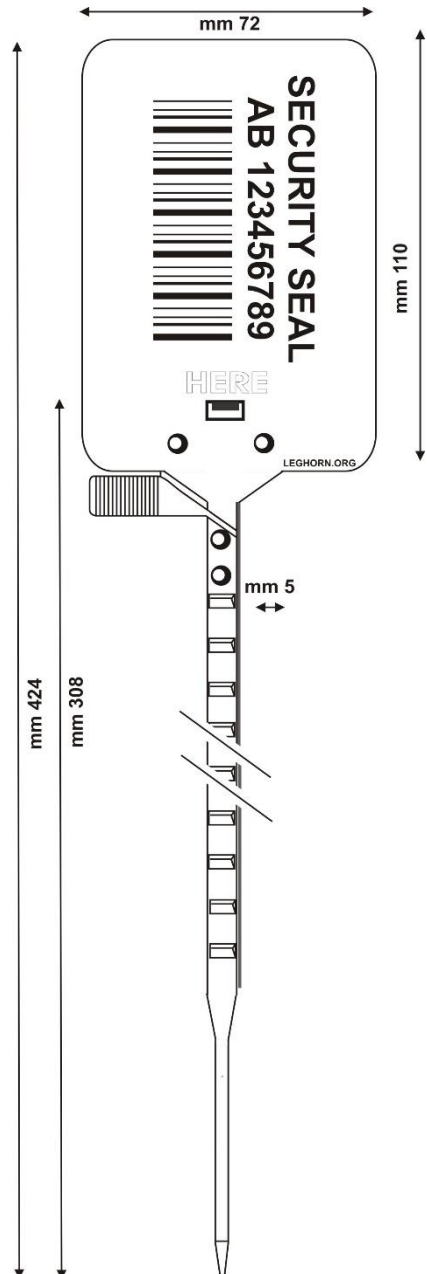

HERACLIS SEAL 5x298 mm

Adjustable plastic seal – large label 72x80 mm



DESCRIPTION:

Adjustable plastic seal, fully recyclable. Distinctive feature is the large plastic tag that can host a large informative adhesive label.

The product is available in two different versions, pre-cut and no-cut.

Pre-cuts let avoid using unsafe cutting tools that might injury operators.

HERACLIS seal is the best plastic indicative seal for Post-office mailbags or sacks.

Longest product version shows a tail of 394 mm length.

SIZE:

Tail width: 5 mm
Total length: 298 mm
Tag size: 72x80 mm

MATERIAL:

Copolymer polypropylene

NUMBERING AND PERSONALISATION:

Thermal transfer printing:

- Sequential numbering up to 15 digits
- Barcoding
- Up to 20 alphanumeric characters per line
- Customer's logo
- Special customisation on quantities with logo embossing

AVAILABLE COLORS:

Red – Yellow – Blue – Green – White – Black - Orange
Light blue – Grey – Brown – Lilac.

° For special orders, logo printing in relief.

PACKING:

Box of 500 pieces in strip of 5 pieces each
Box size: 56x39x21 cm

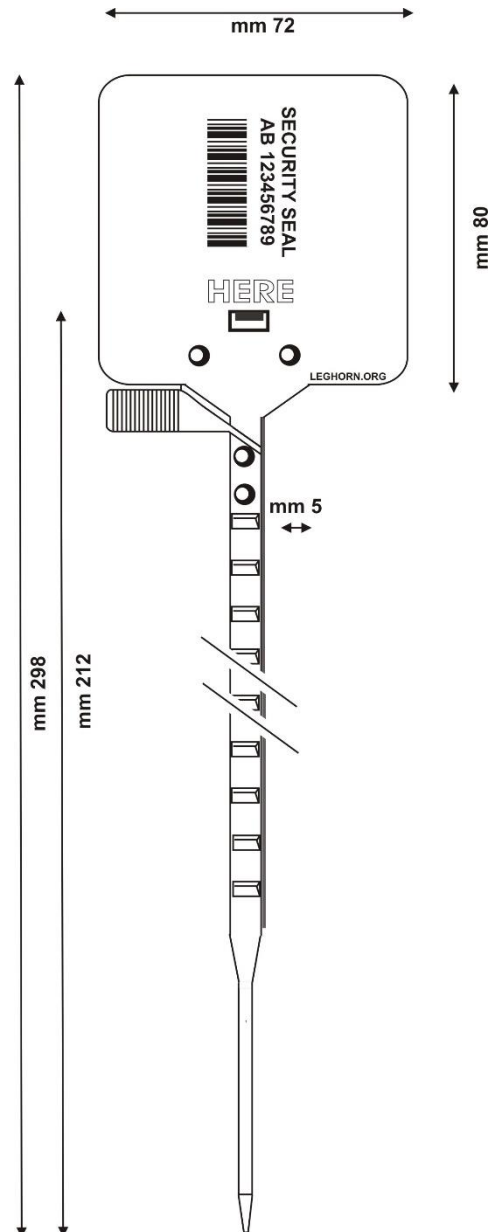

HERACLIS SEAL 5x394 mm

Adjustable plastic seal – large label 72x80 mm



HERACLIS seal is the best plastic indicative seal for Post-office mailbags or sacks.
Longest product version shows a tail of 394 mm length.

SIZE:

Tail width: 5 mm
Total length: 394 mm
Tag size: 72x80 mm

MATERIAL:

Copolymer polypropylene

NUMBERING AND PERSONALISATION:

Thermal transfer printing:

- Sequential numbering up to 15 digits
- Barcoding
- Up to 20 alphanumeric characters per line
- Customer's logo
- Special customisation on quantities with logo embossing

AVAILABLE COLORS:

Red – Yellow – Blue – Green – White – Black - Orange
 Light blue – Grey – Brown – Lilac.
 ° For special orders, logo printing in relief.

PACKING:

Box of 500 pieces in strip of 5 pieces each
 Box size: 56x39x21 cm
 Box weight: 5,2 kgs

DESCRIPTION:

Adjustable plastic seal, fully recyclable.
 Distinctive feature is the large plastic tag that can host a large informative adhesive label.
The product is available in two different versions, pre-cut and no-cut.
 Pre-cuts let avoid using unsafe cutting tools that might injury operators.

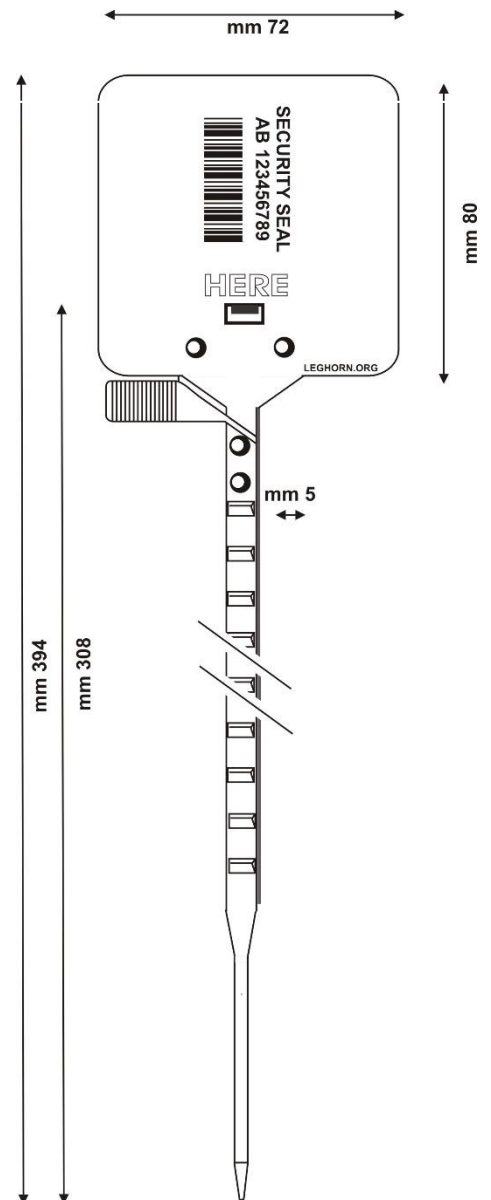

ORIONSEAL 5x258 mm

Adjustable plastic seal – label 72x40 mm



DESCRIPTION:

- ° Adjustable security seals, pull up action for quick application and immediate security.
- ° Tear-off possibility or standard version.

SIZES:

- ° Width : 5 mm
- ° Length : 258 mm
- ° Label : 72x40 mm

MATERIAL:

Copolymer polypropylene

NUMBERING AND PERSONALISATION:

Thermal transfer printing:

- Sequential numbering up to 15 digits
- Barcoding
- Up to 20 alphanumeric characters per line
- Customer's logo
- Special customisation on quantities with logo embossing

AVAILABLE COLORS:

Red – Yellow – Blue – Green – White – Black - Orange
 Light blue – Grey – Brown – Lilac.
 ° For special orders, logo printing in relief.

PACKING:

Carton with 500 seals
 Carton dimensions: 56x39x21 cm
 Carton weight: 3,5 kgs

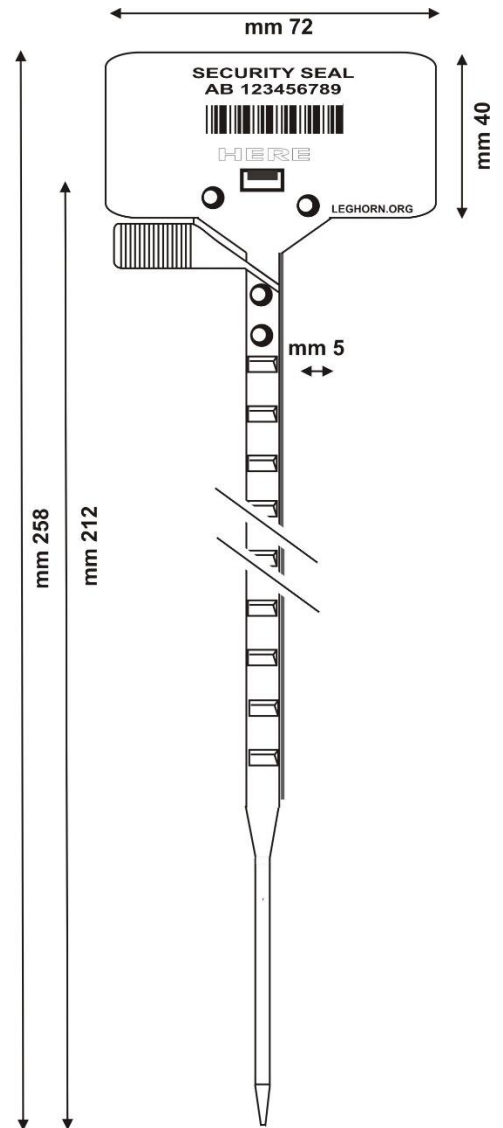

ORIONSEAL 5x354 mm

Adjustable plastic seal – label 72x40 mm



MATERIAL:

Copolymer polypropylene

NUMBERING AND PERSONALISATION:

Thermal transfer printing:

- Sequential numbering up to 15 digits
- Barcoding
- Up to 20 alphanumeric characters per line
- Customer's logo
- Special customisation on quantities with logo embossing

AVAILABLE COLORS:

Red – Yellow – Blue – Green – White – Black
 - Orange Light blue – Grey – Brown – Lilac.
 ° For special orders, logo printing in relief.

PACKING:

Carton with 500 seals
 Carton dimensions: 56x39x21 cm
 Carton weight: 3,7 kgs

DESCRIPTION:

- ° Adjustable security seals, pull up action for quick application and immediate security.
- ° Tear-off possibility or standard version.

SIZES:

- ° Width : 5 mm
- ° Length : 354 mm
- ° Label : 72x40 mm

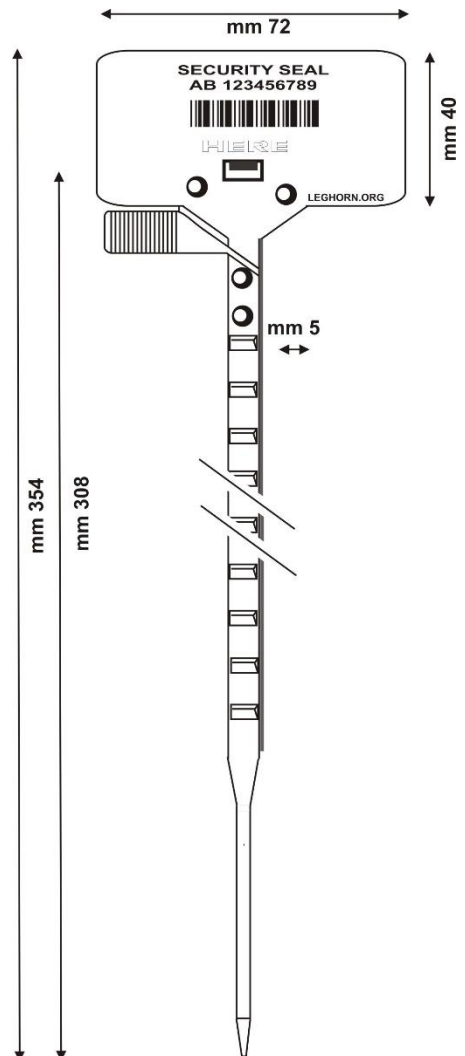

ADJUSTABLE SEAL 3,3x315 mm

Plastic adjustable seal



DESCRIPTION:

° Adjustable security seals, pull up action for quick application and immediate security.

° **Tear-off possibility or standard version.**

SIZES:

- ° Diam : 3,3 mm
- ° Length : 315 mm
- ° Label : 22x50 mm

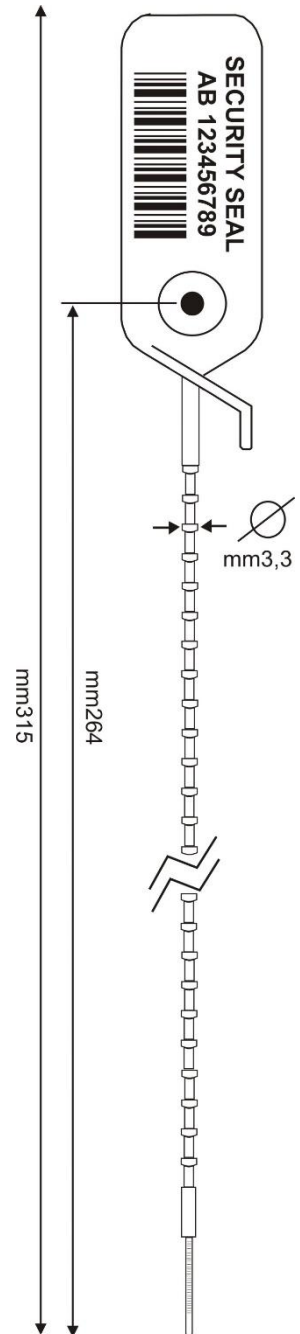

SEQUENTIAL NUMBERING AND CUSTOMISATION:

- ° INK TRANSFER PRINT or laser printing.
- ° Sequenced numbering up to 15 digits.
- ° Bar-code possibility
- ° Customised up to 20 characters on one line
- ° Logos available upon request
- ° For special orders, logo printing in relief.

MATERIAL:

Copolymer polypropylene

AVAILABLE COLORS:

- Red – Yellow – Blue – Green – White – Black - Orange Light blue – Grey – Brown – Lilac.
- ° For special orders, logo printing in relief.

PACKING:

- Carton with 1.000 seals- strip of 10 pcs
- Carton dimensions: 56x33x19 cm
- Carton weight: 3,5 kgs

ADJUSTABLE SEAL 3,3x425 mm

Plastic adjustable seal



DESCRIPTION:

° Adjustable security seals, pull up action for quick application and immediate security.

° Tear-off possibility or standard version.

SIZES:

- ° Diam : 3,3 mm
- ° Length : 425 mm
- ° Label : 22x50 mm

SEQUENTIAL NUMBERING AND CUSTOMISATION:

- ° INK TRANSFER PRINT or laser printing.
- ° Sequenced numbering up to 15 digits.
- ° Bar-code possibility
- ° Customised up to 20 characters on one line
- ° Logos available upon request
- ° For special orders, logo printing in relief.

MATERIAL:

Copolymer polypropylene

AVAILABLE COLORS:

- Red – Yellow – Blue – Green – White – Black - Orange
 Light blue – Grey – Brown – Lilac.
- ° For special orders, logo printing in relief.

PACKING:

Carton with 1.000 seals- strip of 10 pcs
 Carton dimensions: 56x33x24 cm
 Carton weight: 5 kgs

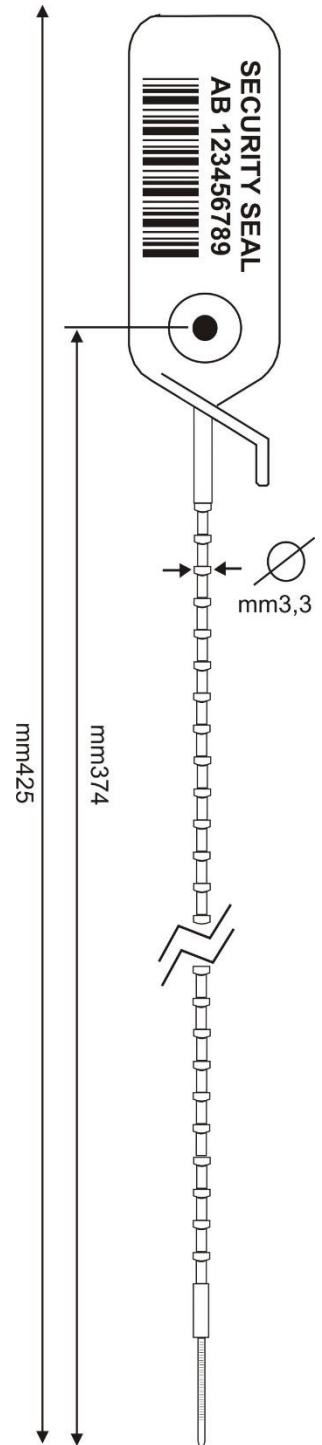

SCITSEAL 3,3x315 or 425 mm Adjustable plastic seal - Ball-lock tail and Metal blocking Closure



DESCRIPTION:

- ° Adjustable plastic seal
- ° Quick and easy to apply
- ° Optional tear-off.
- ° Metal Blocking in the closure

DIMENSIONS:

- ° diameter : 3.3 mm
- ° lengths : 315 mm or 425 mm
- ° label size: 22x50 mm

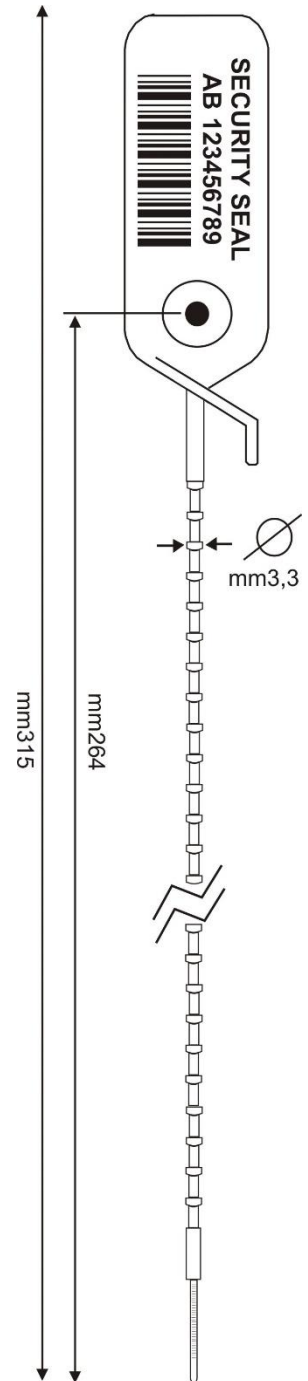

SEQUENTIAL NUMBERING AND CUSTOMISATION:

- ° INK TRANSFER PRINT
- ° Sequenced numbering up to 15 digits.
- ° Bar-code possibility
- ° Customised up to 20 characters on one line
- ° Logos available upon request
- ° For special orders, logo printing in relief.

MATERIAL:

Copolymer polypropylene

AVAILABLE COLORS:

- Red – Yellow – Blue – Green – White – Black - Orange Light blue – Grey – Brown – Lilac.
- ° For special orders, logo printing in relief.

PACKING:

- Carton with 1000 seals - strips of 10 (315 mm)
- Carton size: 56x33x19 cm
- Carton weight: 3.5 kg
- Carton with 1000 seals- strips of 10 (425mm)
- Carton size: 56x33x24 cm
- Carton weight: 5 kgs

SCITSEAL LGH 103 -2x270 mm

Adjustable plastic seal - Ball-lock tail and Metal blocking Closure

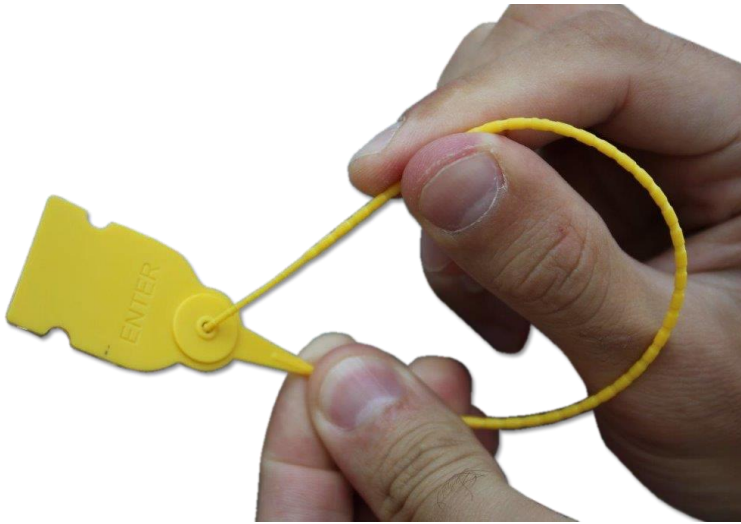

DESCRIPTION:

- ° Adjustable plastic seal
- ° Quick and easy to apply
- ° Metal Blocking in the closure

DIMENSIONS:

- ° diameter : 2 mm
- ° total lengths : 270 mm
- ° Useful lengths: 233 mm

SEQUENTIAL NUMBERING AND CUSTOMISATION:

- ° LASER PRINT
- ° Sequenced numbering up to 15 digits.
- ° Bar-code possibility
- ° Customised up to 20 characters on one line
- ° Logos available upon request
- ° For special orders, logo printing in relief.

AVAILABLE COLORS:

- Red – Yellow – Blue – Green – White – Black - Orange
- Light blue – Grey – Brown – Lilac.
- ° For special orders, logo printing in relief.

PACKING:

- Carton with 1000 seals
- Carton size: 37x24x24 cm
- Carton weight: 2.5 kg

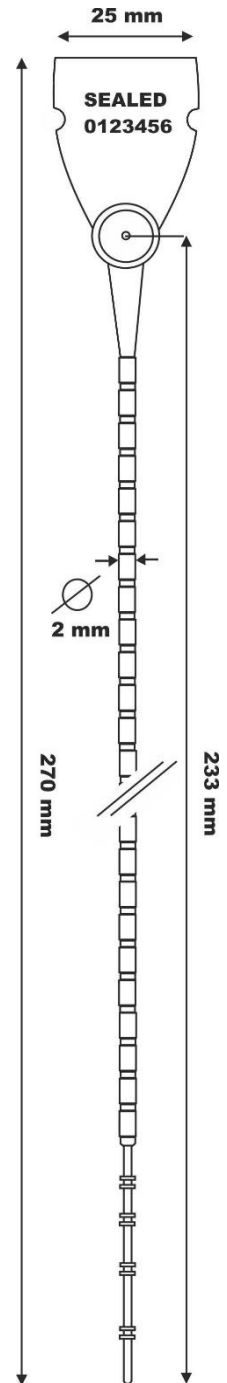

Adjustable plastic seal. Double label (control)



DESCRIPTION:

Adjustable plastic security seal
 Quick and secure application
 Printed with double numbering and tear-off receipt

Size:

- ° Diameter : 2 mm
- ° Length : 315 mm

SEQUENTIAL NUMBERING AND CUSTOMISATION:

- ° INK TRANSFER PRINT
- ° Sequenced numbering up to 15 digits.
- ° Bar-code possibility
- ° Customised up to 20 characters on one line
- ° Logos available upon request
- ° For special orders, logo printing in relief.

MATERIAL:

Copolymer polypropylene

AVAILABLE COLORS:

Red – Yellow – Blue – Green – White – Black - Orange
 Light blue – Grey – Brown – Lilac.
 ° For special orders, logo printing in relief.

PACKING:

Carton with 1000 seals - strips of 10 pieces
 Carton Size: 56x33x19 cm
 Carton Weight: 3.5 kg

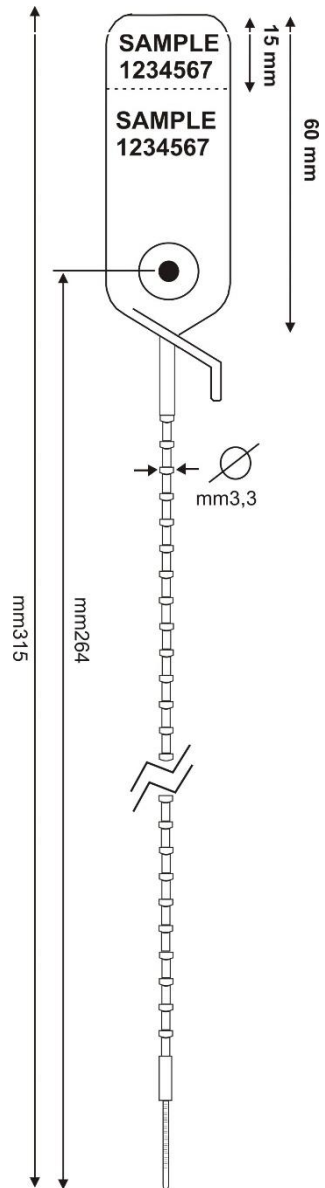

JUPITER SEAL 1,3x225 mm

Plastic adjustable seal – with metal blocking closure

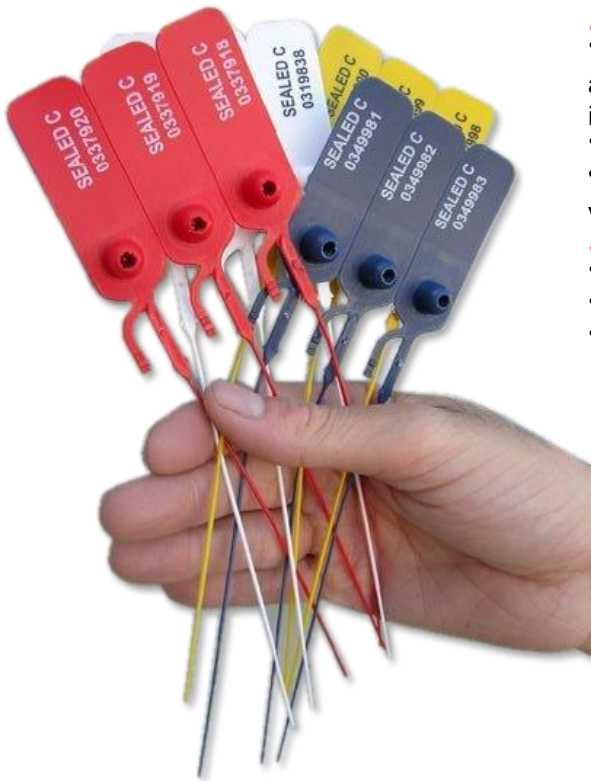

DESCRIPTION:

- ° Adjustable security seals, pull up action for quick application and immediate security.
- ° Metal lock mechanism
- ° **Tear-off possibility or standard** version.

SIZES:

- ° Diam : 1,3 mm
- ° Length : 225 mm
- ° Label : 22x50 mm

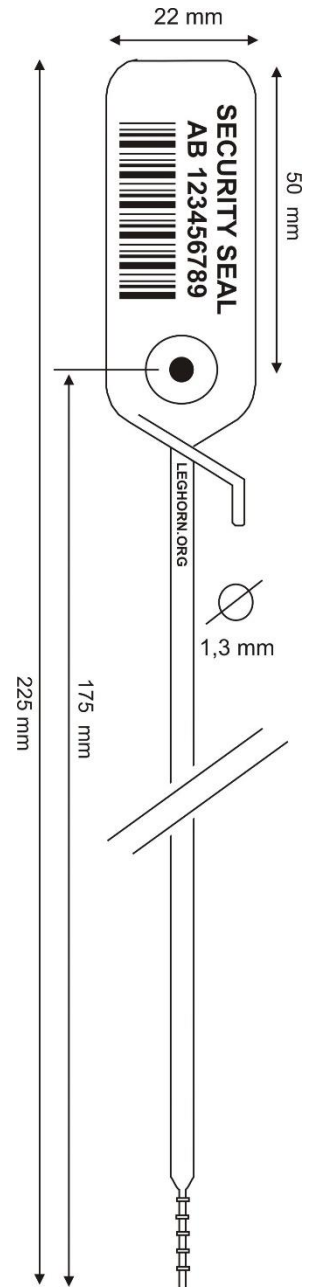

SEQUENTIAL NUMBERING AND CUSTOMISATION:

- ° INK TRANSFER PRINT or laser print.
- ° Sequenced numbering up to 15 digits.
- ° Bar-code possibility
- ° Customised up to 20 characters on one line
- ° Logos available upon request
- ° For special orders, logo printing in relief.

AVAILABLE COLORS:

- Red – Yellow – Blue – Green – White – Black - Orange Light blue – Grey – Brown – Lilac.
- ° For special orders, logo printing in relief.

PACKING:

- Carton with 1.000 seals- strip of 10 pcs
- Carton dimensions: 56x33x19 cm
- Carton weight: 2 kgs

JUPITER SEAL 2x315 mm

Plastic adjustable seal – with metal blocking closure



DESCRIPTION:

- ° Adjustable security seals, pull up action for quick application and immediate security.
- ° Metal lock mechanism
- ° **Tear-off possibility or standard version.**

SIZES:

- ° Diam : 2 mm
- ° Length : 425 mm
- ° Label : 22x50 mm

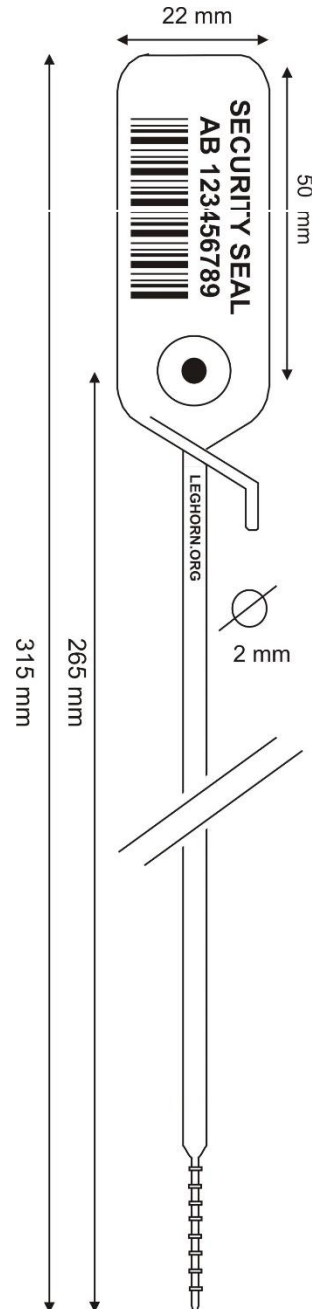

SEQUENTIAL NUMBERING AND CUSTOMISATION:

- ° INK TRANSFER PRINT or laser print.
- ° Sequenced numbering up to 15 digits.
- ° Bar-code possibility
- ° Customised up to 20 characters on one line
- ° Logos available upon request
- ° For special orders, logo printing in relief.

AVAILABLE COLORS:

- Red – Yellow – Blue – Green – White – Black - Orange Light blue – Grey – Brown – Lilac.
- ° For special orders, logo printing in relief.

PACKING:

- Carton with 1.000 seals- strip of 10 pcs
- Carton dimensions: 56x34x25 cm
- Carton weight: 3,5 kgs

JUPITER SEAL 2x425 mm

Plastic adjustable seal – with metal blocking closure

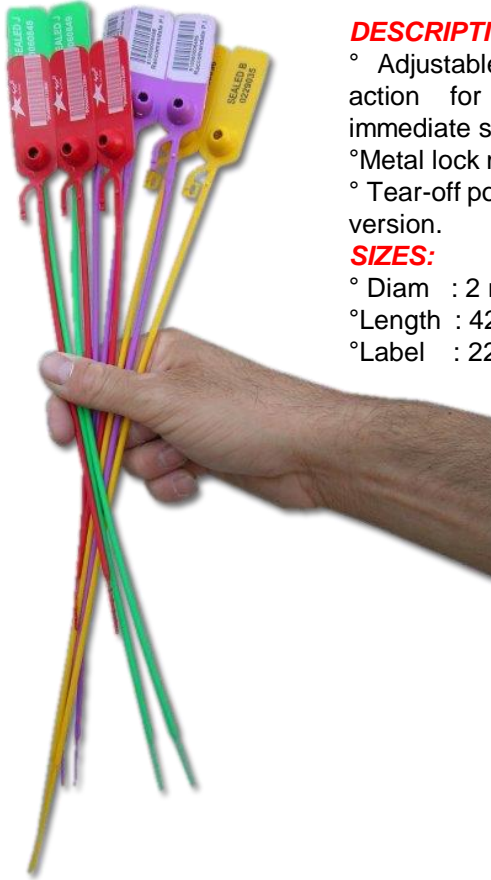

DESCRIPTION:

- ° Adjustable security seals, pull up action for quick application and immediate security.
- ° Metal lock mechanism
- ° Tear-off possibility or standard version.

SIZES:

- ° Diam : 2 mm
- ° Length : 425 mm
- ° Label : 22x50 mm

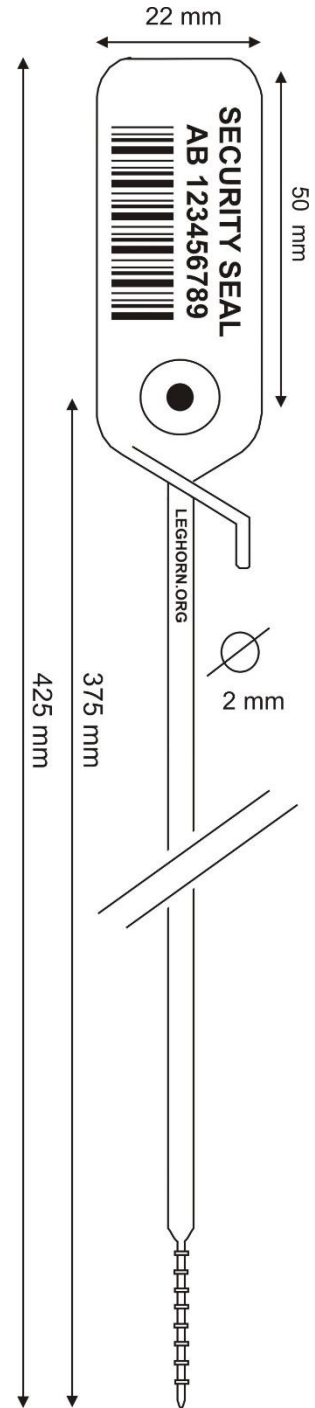

SEQUENTIAL NUMBERING AND CUSTOMISATION:

- ° INK TRANSFER PRINT or laser print.
- ° Sequenced numbering up to 15 digits.
- ° Bar-code possibility
- ° Customised up to 20 characters on one line
- ° Logos available upon request
- ° For special orders, logo printing in relief.

AVAILABLE COLORS:

- Red – Yellow – Blue – Green – White – Black – Orange – Light blue – Grey – Brown – Lilac.
- ° For special orders, logo printing in relief.

PACKING:

- Carton with 1.000 seals- strip of 10 pcs
- Carton dimensions: 56x34x25 cm
- Carton weight: 3,5 kgs

JUPITER SEAL 3,3x315 mm

Plastic adjustable seal – with metal blocking closure

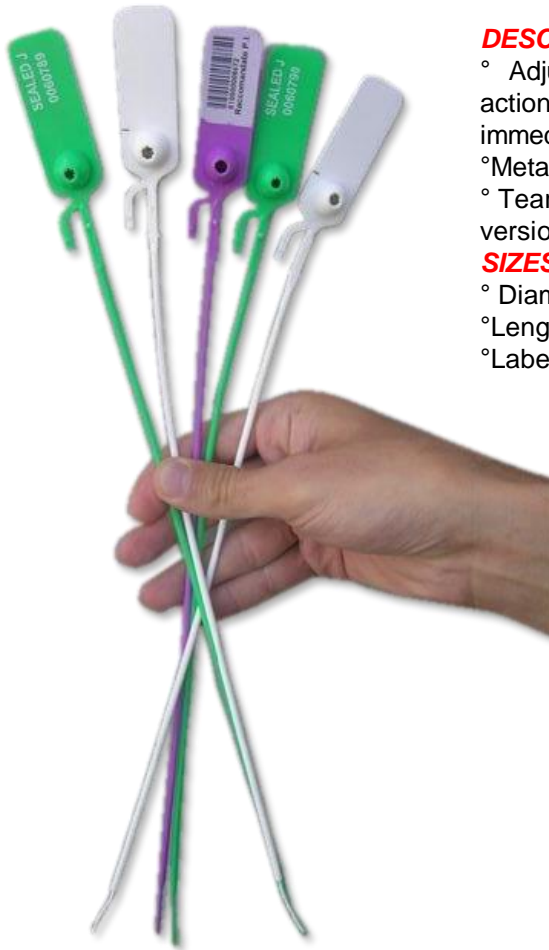

DESCRIPTION:

- ° Adjustable security seals, pull up action for quick application and immediate security.
- ° Metal lock mechanism
- ° Tear-off possibility or standard version.

SIZES:

- ° Diam : 3,3 mm
- ° Length : 315 mm
- ° Label : 22x50 mm

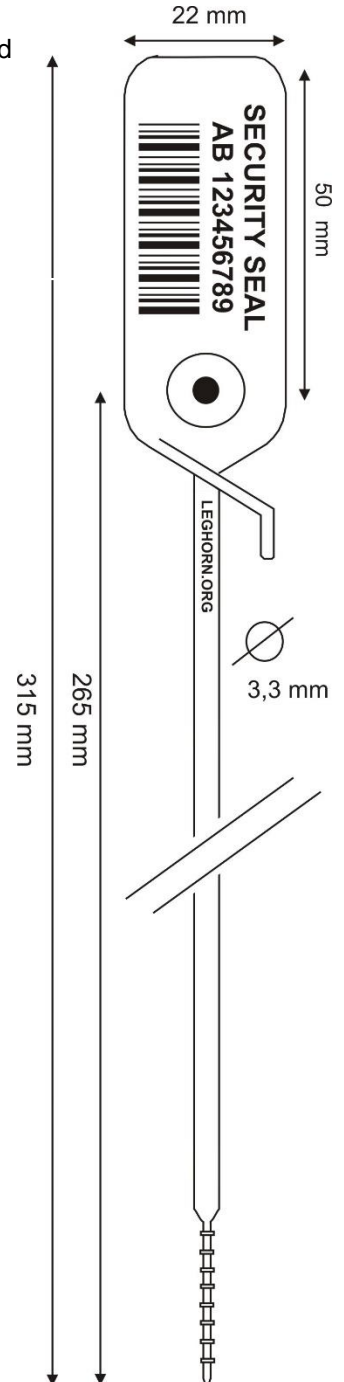

SEQUENTIAL NUMBERING AND CUSTOMISATION:

- ° INK TRANSFER PRINT or laser print.
- ° Sequenced numbering up to 15 digits.
- ° Bar-code possibility
- ° Customised up to 20 characters on one line
- ° Logos available upon request
- ° For special orders, logo printing in relief.

AVAILABLE COLORS:

- Red – Yellow – Blue – Green – White – Black – Orange – Light blue – Grey – Brown – Lilac.
- ° For special orders, logo printing in relief.

PACKING:

- Carton with 1.000 seals- strip of 10 pcs
- Carton dimensions: 56x34x20 cm
- Carton weight: 4 kgs

JUPITER SEAL 3,3x425 mm

Plastic adjustable seal – with metal blocking closure



DESCRIPTION:

- ° Adjustable security seals, pull up action for quick application and immediate security.
- ° Metal lock mechanism
- ° Tear-off possibility or standard version.

SIZES:

- ° Diam : 3,3 mm
- ° Length : 425 mm
- ° Label : 22x50 mm

SEQUENTIAL NUMBERING AND CUSTOMISATION:

- ° INK TRANSFER PRINT or laser print.
- ° Sequenced numbering up to 15 digits.
- ° Bar-code possibility
- ° Customised up to 20 characters on one line
- ° Logos available upon request
- ° For special orders, logo printing in relief.

AVAILABLE COLORS:

- Red – Yellow – Blue – Green – White – Black – Orange – Light blue – Grey – Brown – Lilac.
- ° For special orders, logo printing in relief.

PACKING:

- Carton with 1.000 seals- strip of 10 pcs
- Carton dimensions: 56x34x25 cm
- Carton weight: 4,5 kgs

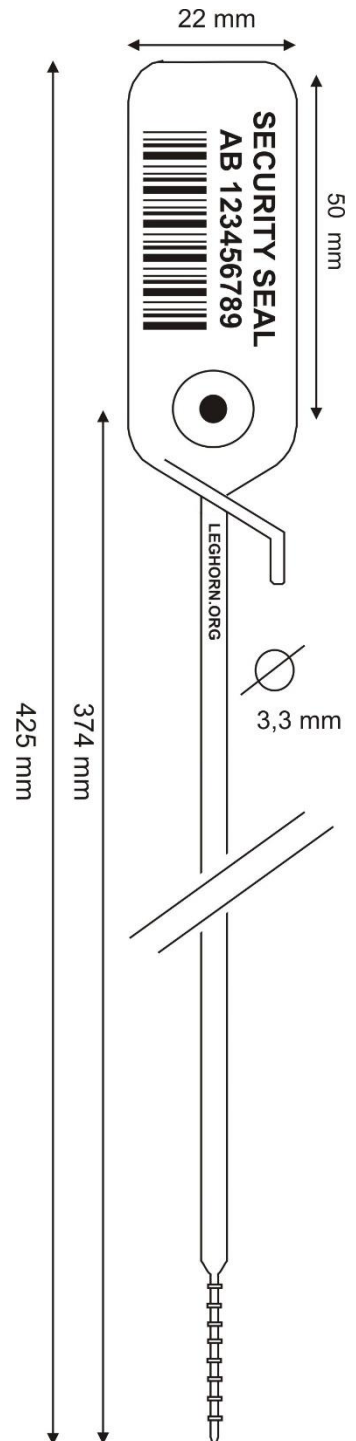

HECTORSEAL 7,5x430 mm

Plastic adjustable seal - with metal blocking closure



DESCRIPTION:

Very sturdy plastic seal. HECTORSEAL LT closure system has a metal insert and also the seal is realized with and without pre-cutting.

HECTORSEAL LT is serially numbered and joined in strips of 10 numbered pieces each strip.

When a product with the same features but with longer length is needed, LEGHORN can offer the longer version of the HECTORSEAL LT adjustable seal: HECTORSEAL LT 7,5x510 mm long.

For the maximum security this seal must be closed as much as possible by pulling tightly the tail so that the closure adheres the item to be sealed.

The part of tail that is not used should be cut.

The uses of this rugged plastic seal are various: HECTORSEAL LT can be used to seal any means of transport or to close large-sized bags.

SIZE:

Width: 7,5 mm

Length: 430 mm

NUMBERING AND PERSONALISATION:

Laser print.

15 digits sequential numbering

Barcoding

Up to 20 alphanumeric characters per line

Customer's logo

Special customisation on quantities with embossed logo

AVAILABLE COLORS:

Red – Yellow – Blue – Green – White – Black - Orange Light blue – Grey – Brown – Lilac.

° For special orders, logo printing in relief.

PACKAGE:

Carton of 1.000 pcs.

Carton size: 44x40x24 cm

Carton weight: 7,5 kg

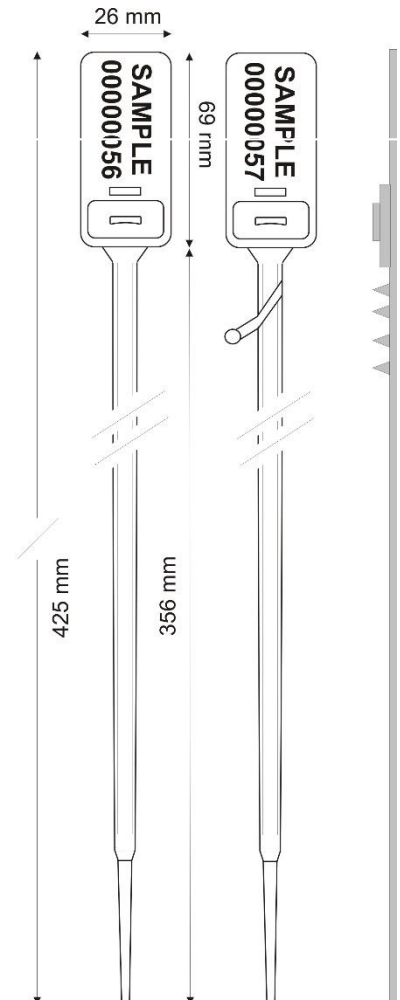



DESCRIPTION:

DRUMLOCK series includes three different types of seal, specifically designed to lock the tie-type closure of drums.

Different sizes are available to meet any need of various drum locking systems.

Once that DRUMLOCK has been properly put in place, the only way to open the drum is by breaking the seal, thus providing evidence of tamper.

PERSONALISATION AND NUMBERING:

No numbering

Embossed logo on demand (for volume quantities)

MATERIAL:

Polypropilene

SIMILAR PRODUCTS:

Small T.B. DRUMLOCK

Standard T.B. DRUMLOCK

T.C. DRUMLOCK

DRUMSEAL (numbered)

AVAILABLE COLORS:

Red – Yellow – Blue – Green – White – Black - Orange Light blue – Grey – Brown – Lilac.

PACKAGE:

T.B. STANDARD: Carton with 10.000 pcs

Carton size: 60x40x40 cm

Carton weight: 10 kg

T.B. SMA: Carton with 20.000 pcs

Carton size: 60x40x20 cm

Carton weight: 8 kg

T.C.: Carton with 10.000 pcs

Carton size: 60x40x40 cm

Carton weight: 10 kg

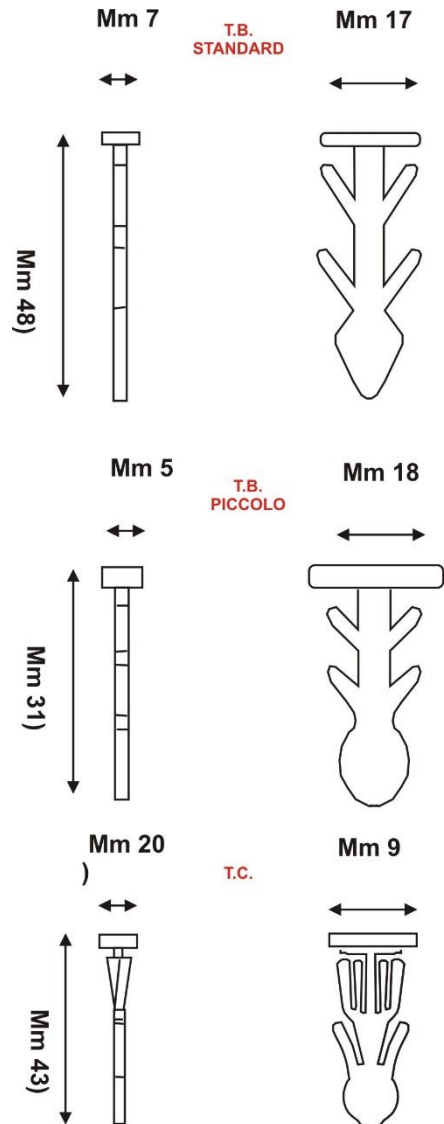



DESCRIPTION:

- ° Key Features
- Specially designed locking mechanism for specific models of tote boxes
- Easily sealed.
- Requires no tool for removal.

CUSTOMISATION:

- ° For special orders, logo printing in relief.

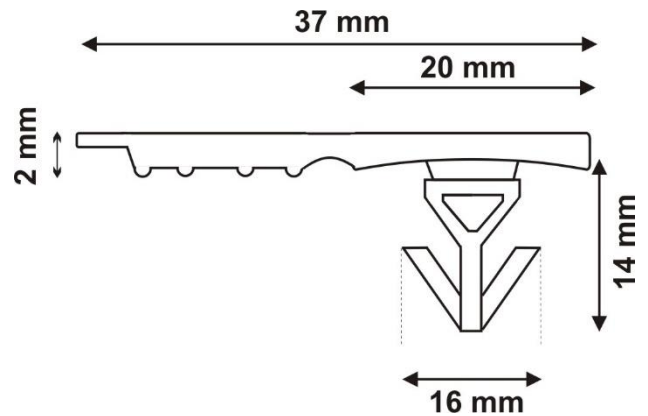

MATERIAL:

Polypropilene

AVAILABLE COLORS:

Red – Yellow – Blue – Green – White – Black - Orange Light blue – Grey – Brown – Lilac.

PACKING:

Carton with 1.000seals
 Carton dimensions: 15x15x21 cm
 Carton weight: 1,2 kgs

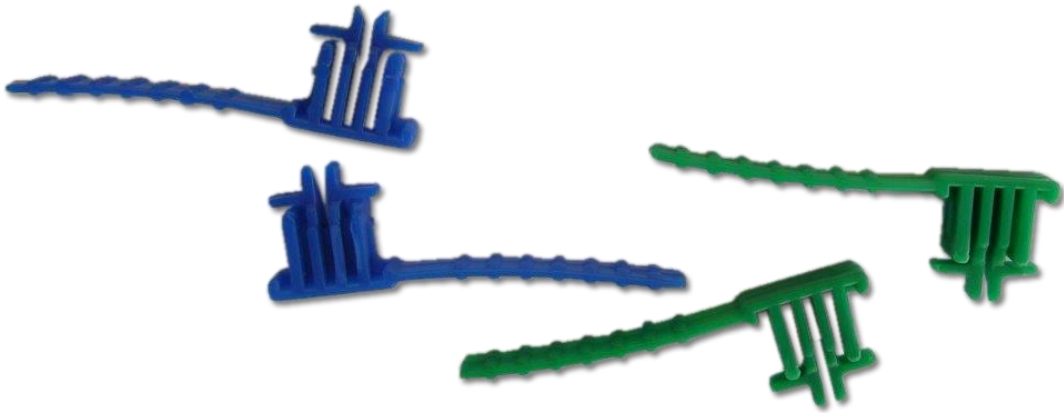

DESCRIPTION:

° The **POSTALBLOCK A1** is a plastic closure that can be used several times.
A light pressure with the fingers is enough to let the mechanism “click” in.

RESISTANCE TEST :

° CARRIED OUT FROM – 30° TO + 60°



CUSTOMISATION:

° For special orders, logo printing in relief.

AVAILABLE COLORS:

Red – Yellow – Blue – Green – White –
Black - Orange Light blue – Grey – Brown –
Lilac.

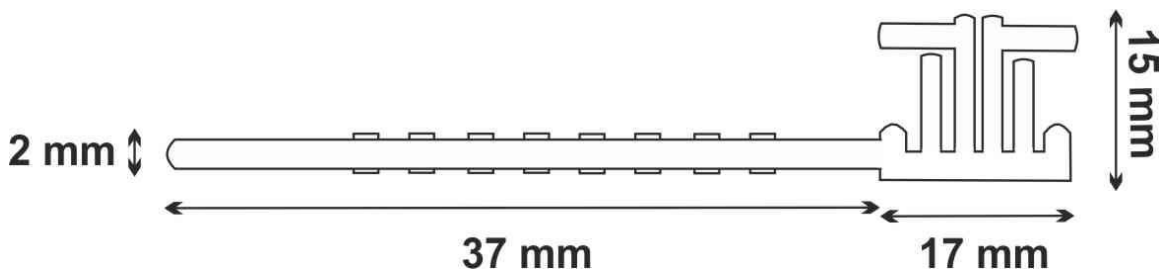



DESCRIPTION:

Plastic seal to stop the closure of the security bag when the head is inserted into the zip, the zip is blocked and to move the zip it is necessary to break the seal.

SEQUENTIAL NUMBERING AND CUSTOMISATION:

- ° LASER PRINT
- ° Sequenced numbering up to 15 digits.
- ° Bar-code possibility
- ° Customised up to 20 characters on one line
- ° Logos available upon request
- ° For special orders, logo printing in relief.

AVAILABLE COLORS:

Red – Yellow – Blue – Green – White – Black - Orange Light blue – Grey – Brown – Lilac.

PACKING:

ZIPSTOP STANDARD :Carton with 5.000 seals
Carton dimensions: 28x21x10 cm
Carton weight: 2,5 kgs

PACKING:

ZIPSTOP BARCODE :Carton with 2.500 seals
Carton dimensions: 28x21x10 cm
Carton weight: 3 kgs

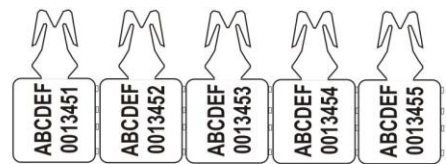
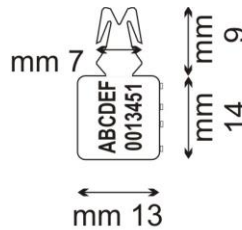

ZIPSTOP STANDARD

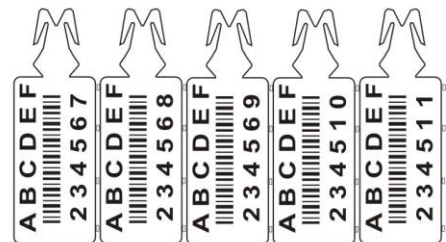

ZIPSTOP LONG FOR BARCODE

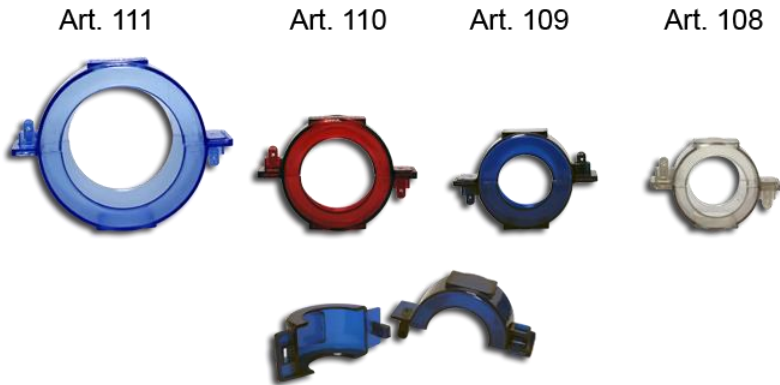

AVAILABLE COLORS:

Red – Yellow – Blue – Green – White – Black – Orange –
Light blue – Grey – Brown – Lilac.

PACKING:

Art: 311

Carton with 500 seals
Carton dimensions: 40x60x35 cm
Carton weight: 13 kgs

Art: 312

Carton with 500 seals
Carton dimensions: 40x60x38 cm
Carton weight: 13 kgs

Art: 313

Carton with 500 seals
Carton dimensions: 40x60x35 cm
Carton weight: 14 kgs

Art: 314

Carton with 250 seals
Carton dimensions: 40x60x35 cm
Carton weight: 9 kgs

DESCRIPTION:

- ° **Connectionlock** is a simple and effective system to protect the pipe-fittings of meters.
- ° The transparent plastic allows visual control of integrity of the fitting itself.
- ° **Connectionlock** works like a seal because it consists in two parts fitting permanently one into the other
- ° There is no way to remove Connectionlock without breaking it.
- ° Once positioned on the pipe-fitting, it is possible to ensure it with a consequentially numbered wire seal. (TWISTSEAL)
- ° **By this way maximum security is achieved.**

MATERIAL:

- ° Polycarbonate (PC)

SEQUENTIAL NUMBERING AND CUSTOMISATION:

- ° INK JET PRINT or laser print
- ° Sequenced numbering up to 6 digits. (NOT NECESSARY)
- ° Customised up to 20 characters on one line
- ° Logos available upon request.

- ° For special orders, logo printing in relief

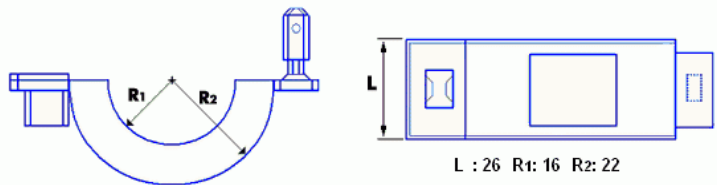

SIZES:

- ° **ART 311** : L:26mm R1: 16mm R2: 22mm
Fit to DN20 (3/4") meters
- ° **ART 312** : L:30mm R1: 16mm R2: 24,5mm
Fit to DN20 (3/4") bold fittings
- ° **ART 313** : L:28mm R1: 19mm R2: 27mm
Fit to DN25 (1") meters
- ° **ART 314** : L:38mm R1: 29mm R2: 39mm
Fit to DN40 (1½") meters

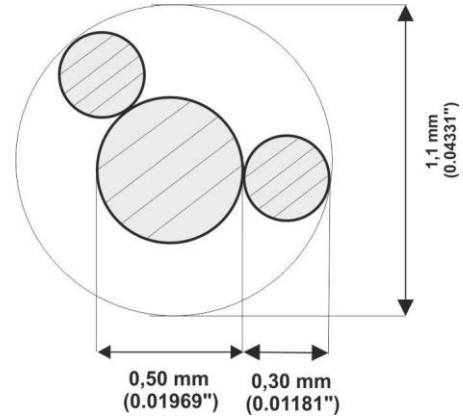
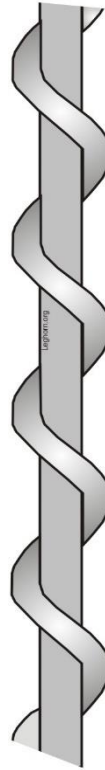

1MM DIAMETER GALVANIZED STEEL SEALING WIRE TECHNICAL DATA TABLE

MATERIAL CLASSIFICATION:

GALVANIZED STEEL ANNEALED

COMPOSITION:

Core wire: \varnothing mm 0.50 - Spiral wire: \varnothing mm 0.30

STRENGTH PER METRE: 2,45g (1 Kg = 400 m ca)

STRUCTURAL

CARACTERISTICS:

COIL DISTANCE:

2.00 mm (50 coils per 100 mm)

6. SURFACE CARACTERISTICS:

SURFACE STATE: ZINC COATING .

Minimum zinc coating 20gr/m²

CHEMICAL BREAKDOWN:

C%	Mn%	P%	S%
0,08	0,45	0,035	0,035

MECHANICAL CHARACTERISTICS:

TOTAL DIAMETER mm	TOLERANCE \varnothing	BREAKING LOAD N/mm ²
1	10%	300/450

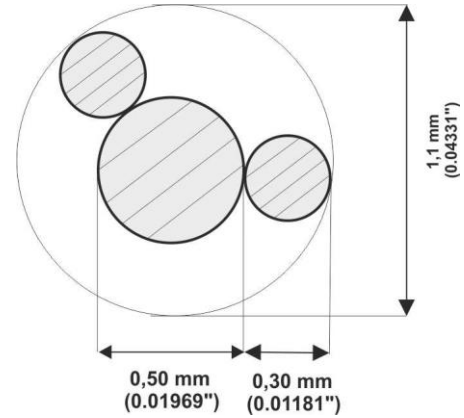

1MM DIAMETER STAINLESS STEEL SEALING WIRE TECHNICAL DATA TABLE

MATERIAL CLASSIFICATION:

Annealed steel AISI 304

COMPOSITION:

Core wire:

Ø mm 0.50 - Spiral wire: Ø mm 0.30

STRENGTH PER METRE: 2,45g (1 Kg = 400 m ca)

STRUCTURAL CHARACTERISTICS:

COIL DISTANCE: 2.00 mm (50 coils per 100 mm)

SURFACE CHARACTERISTICS:

SURFACE STATE: GLOSS

CHEMICAL BREAKDOWN:

C%	Mn %	Si%	Ni%	Cr%	P%	S%
<= 0.08	<= 2.00	<= 1.00	8.00 - 10.50	18.00 - 20.00	<= 0.045	<= 0.030

MECHANICAL CHARACTERISTICS

TOTAL DIAMETER mm	TOLERANCE Ø	BREAKING LOAD N/mm ²
1.00	10%	700/750

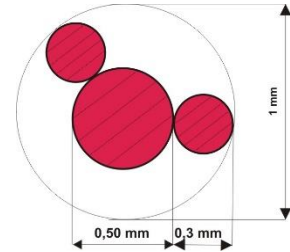
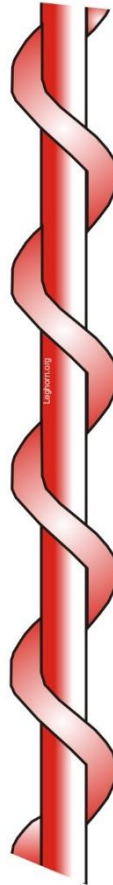

1MM DIAMETER RED COPPER SEALING WIRE TECHNICAL DATA TABLE

MATERIAL CLASSIFICATION:
RED COPPER ANNEALED
ASTM B 49,92 – UNI EN 1977 – 2000

COMPOSITION:

Core wire:

Ø mm 0.50 - Spiral wire: Ø mm 0.30

STRENGTH PER METRE: 2,78g (1 Kg = 360 mt appx)

STRUCTURAL CHARACTERISTICS:

COIL DISTANCE: 2.00 mm (50 coils per 100 mm)

SURFACE CHARACTERISTICS:

SURFACE STATE: GLOSSY

ELONGATION: 23-23%

MECHANICAL CHARACTERISTICS

TOTAL DIAMETER mm	TOLERANCE Ø	BREAKING LOAD N/mm ²
1.00	10%	210/220

CHEMICAL BREAKDOWN

Cu%	Fe%	Pb%	As%	Ag%	Ni%	Sn%	S%
99,974	0,0035	0,0013	0,0011	0,0011	0,0008	0,0009	0,004

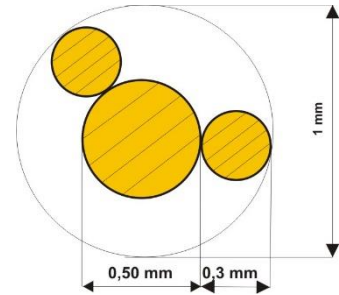
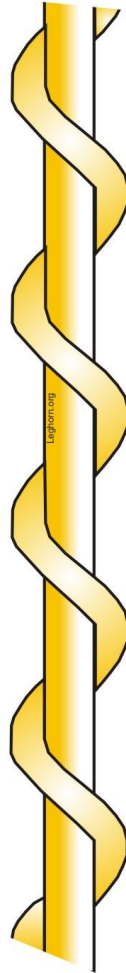

1MM DIAMETER RED BRASS SEALING WIRE TECHNICAL DATA TABLE

MATERIAL CLASSIFICATION: brass
ANNEALED

3. COMPOSITION:

Core wire: Ø mm 0.50 –
Spiral wire: Ø mm 0.30

STRENGTH PER METRE: 2,63g (1 Kg = 380 mt appx)

STRUCTURAL CHARACTERISTICS:
COIL DISTANCE: 2.00 mm (50 coils per 100 mm)

SURFACE CHARACTERISTICS:
SURFACE STATE: GLOSSY

MECHANICAL CHARACTERISTICS

TOTAL DIAMETER mm	TOLERANCE Ø	BREAKING LOAD N/mm ²
1.00	10%	400/430

CHEMICAL BREAKDOWN

Cu%	Zn%	Pb%	Fe%	Al%	Ni%	Sn%	S%
67,000	32,000	0,010	0,0014	0,010	0,049	0,016	0,05

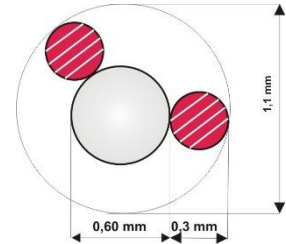
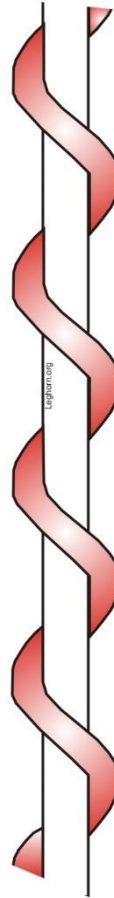

1,1 MM DIAMETER NYLON COPPER SEALING WIRE TECHNICAL DATA TABLE

1. MATERIAL CLASSIFICATION:

Nylon - Copper

2. COMPOSITION: Core nylon : Ø 0.6 mm - 100% Poliammide
Spiral: red ANNEALED copper : Ø 0.3 mm . in conformity of ASTM 49,92 – UNI EN 1977 - 2000

STRENGTH PER METRE: 1,50g (1 Kg = 650 m ca)

5. STRUCTURAL CHARACTERISTICS:

COIL DISTANCE: 1,50 mm (66 coils per 100 mm)

MECHANICAL CHARACTERISTICS

TOTAL DIAMETER mm	TOLERANCE Ø	BREAKING LOAD N/mm ²
1.00	10%	159/178

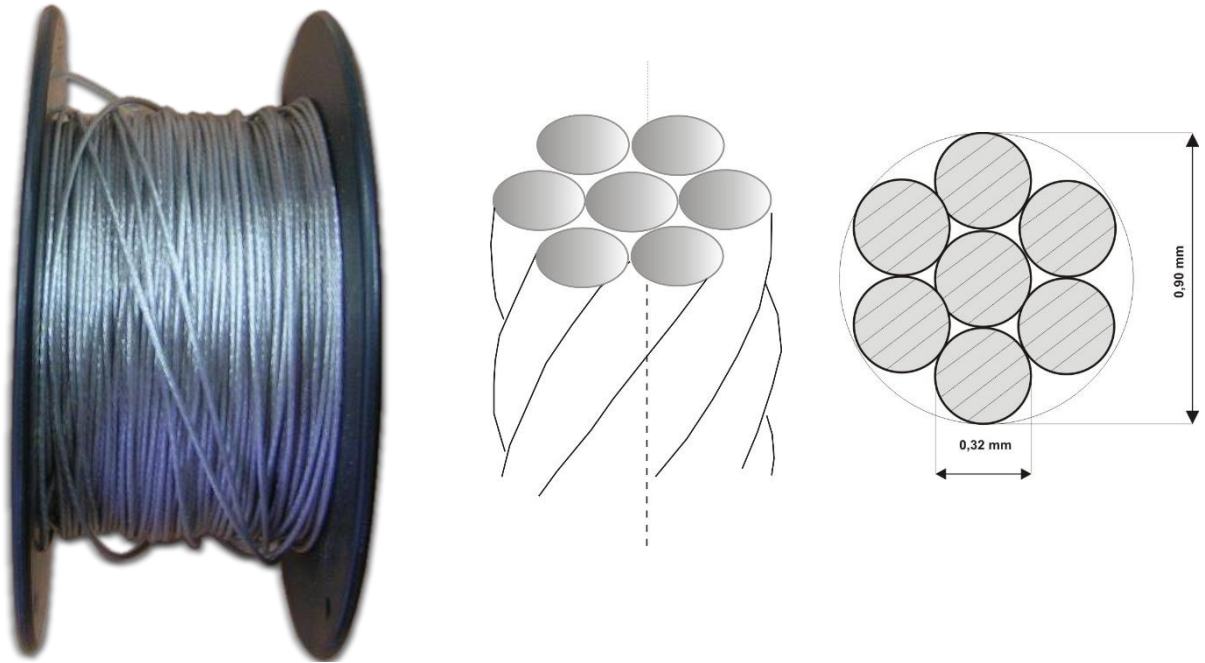
**DESCRIPTION:**

- ° Seven stainless steel wire diam: 0,32 mm. transparent plastic covered.
- ° Total diam 0,90 mm
- ° Inox Steel cable approximate weights and lengths
- ° 1kg reel is equal to 406m
- ° 250m reel is equal to 675g
- ° 500m reel is equal to 1440g
- ° 1000m reel is equal to 2960g

1 MM DIAMETER STAINLESS STEEL SEALING WIRE TECHNICAL DATA

GRADE	N.W. (kg)	TS (Mpa)	EL %
304	483,88	785	75

1 MM DIAMETER STAINLESS STEEL SEALING WIRE CHEMICAL COMPOSITION (%)

C	Si	Mn	P	S	Cr	Ni
0,03	0,43	1,30	0,026	0,008	18,23	8,03

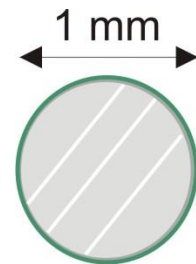
**DESCRIPTION:**

Plastic covered wire :diam. 1 mm

Standard colour: green

All colors available:

minimum quantity 108 reels 200 gr each

Each reel:

200 gr = 120 metres

STANDARD COLOURS

Green – white

PACKING:

1 Carton : 108 reels

Carton sizes: 38x38x24 cm

Carton weight : 2,5 kgs

We can also produce seals according Customer's model.

Timing for the realization of the project			
Drawing	After drawing approved	After 3D model approved	After approval
7-10 days	7-10 days = 3D model	60-70 days Mold and first samples	Start production
Production capacity: 1.000.000 pieces per month per mold, by one work shift			

WORLD CONTACTS

71

General e-mail: info@leghorngroup.com



LeghornGroup ITALY
www.leghorngroup.it

LeghornGroup USA
www.leghorngroup.co

LeghornGroup BELGIUM
www.leghorngroup.be
www.leghorngroup.nl

LeghornGroup SAUDI ARABIA
www.leghorngroup.sa

LeghornGroup CZECH REP.
www.leghorngroup.cz
www.leghorngroup.pl

LeghornGroup GREECE
www.leghorngroup.gr

LeghornGroup MOLDOVA
www.leghorngroup.ro

LeghornGroup SPAIN
www.leghorngroup.es



LeghornGroup

Protection - Control - Identification - Tracking

Since 1978

LeghornGroup srl

34/36, Via degli Arrotini - 57121 Livorno, Tuscany, Italy

Ph: +39 0586 406376 - Fax:+39 0586 407621 – www.leghorngroup.com - info@leghorngroup.com

PROTECTION – CONTROL - IDENTIFICATION – TRACKING